



**DATA SHEET DIESEL  
GENERATOR SET** 

---

**GSBD23300S-UL**



► Model

**GSBD23300S-UL**

- ENGINE BRAND >> BAUDOIN
- ENGINE MODEL >> 16M55G8D2/6
- ALTERNATOR BRAND >> STAMFORD
- GENERATOR CONTROLLER >> DSE 7310

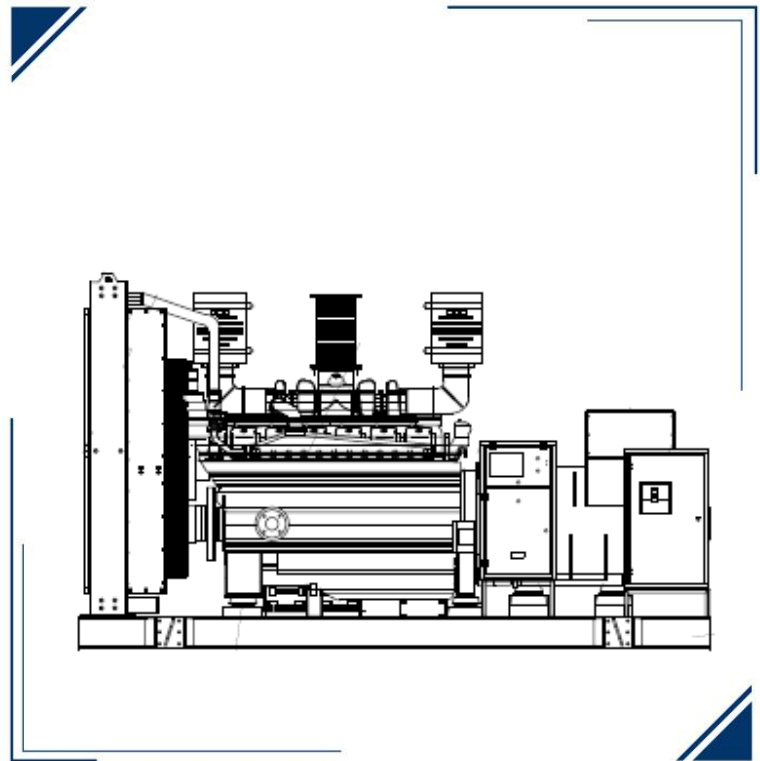

► GENSET RATING

ENGINE	ALTERNATOR	VOLTAGE	PH	Hz	STANDBY POWER		POWER FACTOR	CURRENT
		V			kW	KVA		A
	P80LVS1804W	480/277	3	60	3300	4125	0.8	4967
16M55G8D2/6	P80LVS1804W	600	3	60	3300	4125	0.8	3973

► Certifications



**Standby Power.** Applicable for supplying power to varying electrical load for the duration of power interruption of a reliable utility source. Emergency Standby Power (ESP) is in accordance with ISO 8528. Fuel Stop power in accordance with ISO 3046, AS 2789, DIN 6271 and BS 5514.

## ► ENGINE FEATURES

» BRAND _____	► BAUDOQUIN
» MODEL _____	► 16M55G8D2/6
» EXHAUST EMISSIONS _____	► TIER 2
» RPM _____	► 1800
» STANDBY RATING kWm _____	► 3600
» STANDBY RATING bhp _____	► 4828
» PRIME RATING kWm _____	► 3300
» PRIME RATING bhp _____	► 4425
» NUMBER OF CYLINDERS _____	► 16
» ASPIRATION _____	► TURBOCHARGED AND AFTERCOOLED
» DISPLACEMENT in <sup>3</sup> _____	► 5321.3
» ENGINE AIR FLOW CFM _____	► 9128.8
» GOVERNOR TYPE _____	► ELECTRONIC
» CONTROL VOLTAGE v _____	► 24
» BORE/STROKE, in ( _____	► 7.08X8.46(180X215)
» COOLANT CAPACITY WITHOUT RADIATOR gal _____	► 92.6
» OIL CAPACITY, TOTAL gal _____	► 153.8

## ► FUEL CONSUMPTION

STANDBY POWER		
LOAD	GAL/hr	L/hr
100%	234.5	887.5
75%	173.4	656.5
50%	121.1	458.3
25%	70	264.9

## ► ALTERNATOR FEATURES

» BRAND _____	► STAMFORD
» MODEL _____	► P80LVS1804W
» FREQUENCY _____	► 60 Hz
» PHASES _____	► 3
» WINDING LEADS _____	► 6
» INSULATION SYSTEM _____	► H CLASS
» CONTROL SYSTEM _____	► SEPARATELY EXCITED BY P.M.G.
» PROTECTION _____	► IP23
» POWER FACTOR _____	► 0.8
» COOLING AIR CFM _____	►
» VOLTAGE REGULATION (%) _____	► +-0.5

## ► GENERATOR CONTROLLER

### » MODEL

## DEEP SEA 7310



The DSE7310 MKII is an Auto Start Control Module and the DSE7320MKII is an Auto Mains (Utility) Failure Control Module suitable for a wide variety of single, diesel or gas, gen-set applications.

Monitoring an extensive number of engine parameters, the modules will display warnings, shutdown and engine status information on the back-lit LCD screen, illuminated LEDs, remote PC and via SMS text alerts (with external modem). The DSE7320 MKII will also monitor the mains (utility) supply. The modules include USB, RS232 and RS485 ports as well as dedicated DSENet@ terminals for system expansion.

#### KEY FEATURES

- 4-Line back-lit LCD text display
- Multiple Display Languages
- Five key menu navigation
- LCD alarm indication
- DSENet expansion compatibility
- Internal PLC editor
- Protections disable feature
- Fully configurable via PC using USB, RS232 & RS485 communication
- Front panel configuration with PIN protection
- Power save mode
- 3 phase generator sensing and protection
- 3 phase mains (utility) sensing and protection (DSE7320 MKII only)
- Automatic load transfer control (DSE7320 MKII only)
- Generator current and power monitoring (kW, kvar, kVA, pf)
- Mains current and power monitoring (kW, kvar, kVA, pf) (DSE7320 MKII only)
- kW and kvar overload and reverse power alarms

- Over current protection
- Unbalanced load protection
- Independent earth fault protection
- Breaker control via fascia buttons
- Fuel and start outputs configurable when using CAN
- 6 configurable DC outputs
- 2 configurable volt-free relay outputs
- 6 configurable analogue/digital inputs
- Support for 0 V to 10 V & 4 mA to 20 mA sensors
- 8 configurable digital inputs
- Configurable 5 stage dummy load and load shedding outputs
- CAN, MPU and alternator frequency speed sensing in one variant
- Real time clock
- Manual and automatic fuel pump control
- Engine pre-heat and post-heat functions
- Engine run-time scheduler
- Engine idle control for starting & stopping
- Fuel usage monitor and low fuel level alarms
- Simultaneous use of RS232 and RS485 communication ports
- True dual mutual standby using RS232 or RS485 for accurate engine hours balancing.
- MODBUS RTU support with configurable MODBUS pages.
- Advanced SMS messaging (additional external modem required)
- Start & stop capability via SMS messaging
- 3 configurable maintenance alarms
- Compatible with a wide range of CAN engines, including tier 4 engine support

- Uses DSE Configuration Suite PC Software for simplified configuration
- Licence-free PC software
- IP65 rating (with supplied gasket) offers increased resistance to water ingress
- Modules can be integrated into building management systems (BMS) using MODBUS RTU

#### KEY BENEFITS

- Automatically transfers between mains (utility) and generator (DSE7320 MKII only) for convenience.
- Hours counter provides accurate information for monitoring and maintenance periods
- User-friendly set-up and button layout for ease of use
- Multiple parameters are monitored & displayed simultaneously for full visibility
- The module can be configured to suit a wide range of applications for user flexibility
- PLC editor allows user configurable functions to meet user specific application requirements.

## ► DIMENSIONS AND WEIGHT

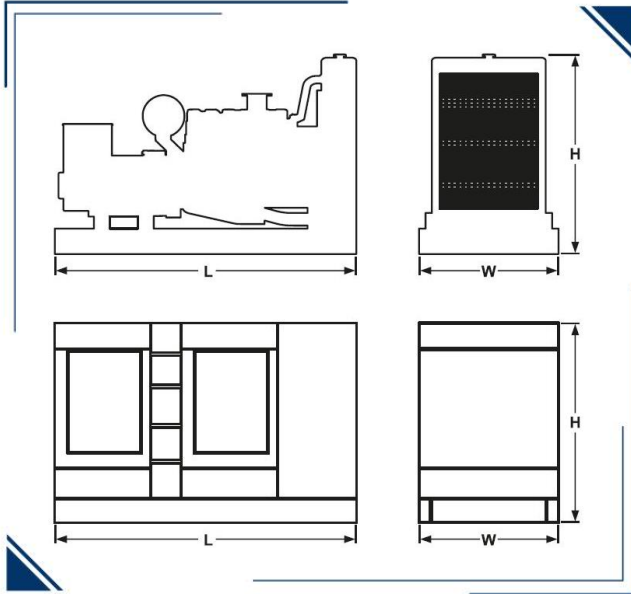

OPEN GENSET					
DIMENSION	Length (L)	Width (W)	Height (H)	Weight	Noise Level
	IN			Lbs	dB
	315	118	143		
ENCLOSED GENSET LEVEL 2					
DIMENSION	Length (L)	Width (W)	Height (H)	Weight	Noise Level
	IN			Lbs	dB
	421	134	157		

## ► ACOUSTIC ENCLOSURE

Acoustic enclosure designed and manufactured with 14 gauge carbon steel sheet, polyurethane acoustic coating, access and air expulsion to avoid gas accumulation, drainage system to avoid liquid accumulation. Electrostatic painting for extended life. We have options for enclosures in aluminum or stainless steel

## ► STANDARD FEATURES & ACCESSORIES

<input checked="" type="checkbox"/>	DSE 9470 Battery Charger	<input checked="" type="checkbox"/>	Emergency Stop Button
<input checked="" type="checkbox"/>	Battery and Battery Rack	<input checked="" type="checkbox"/>	Flex Fuel Lines
<input checked="" type="checkbox"/>	ABB Main Line Circuit Breaker	<input checked="" type="checkbox"/>	Protection Covers for Rotating Parts
<input checked="" type="checkbox"/>	AVR	<input checked="" type="checkbox"/>	Exhaust Insulation Cover
<input checked="" type="checkbox"/>	Hotstart Pre heater 2 RMP-CSM10902-000	<input checked="" type="checkbox"/>	Anti Vibration Pads between Engine/Alternator & Base Frame
<input checked="" type="checkbox"/>	Residential Grade Silencer Open Unit	<input checked="" type="checkbox"/>	Operation and Maintenance manuals
<input checked="" type="checkbox"/>	Critical Grade Silencer Inside Enclosure	<input checked="" type="checkbox"/>	24 Months /1000 hours Limited Standby Warranty



## ▶ OPTIONAL ACCESSORIES

Paralleling Adder (DSE8610 & Motorized Breaker)	Enclosure AC light and On/Off Switch
120V GFCI Receptacle	Enclosure DC light and On/Off Switch
240V Receptacle	Enclosure space Heater (1500w/120v)
Alternator Strip Heater	Load Center / Distribution Board (100 A, 12 Breaker)
Battery Blanket Heater	Load Center / Distribution Board (200 A, 8 Breaker)
Battery Disconnect Switch	AVR UPGRADE
Battery Pad Heater	Oil Pan Heater
Battery Restraint	Relay - 10A Common Alarm
Control Panel Heater	Relay - 10A Run Relay
DSE2157 Output Module (8 dry contacts)	Remote E-Stop- Breaker Glass Type / Nema 3R
DSE2520 Remote Display Module	Remote E-Stop- Breaker Glass Type / Nema 4X
DSE2548 Remote Annunciator (16 light)	Remote E-Stop- Flush Mount
DSE2548 Remote Annunciator (24 light)	Remote E-Stop- Surface Mount
DSE2548 Remote Annunciator (8 light)	Remote E-Stop- Visual/ Plastic Hinged Cover
DSE890 3G GATEWAY	Spring Isolator- Non Seismic (ACE 121 Series) <small>SKIRT NOT INCLUDED</small>
GSM/GPS ANTENNA 3M RG-174, GSM-SMA(M), GPS-SMA(F)	Spring Isolator- Seismic/Restraint (ACE 821 Series) <small>SKIRT NOT INCLUDED</small>
DSE9641 10A Battery Charger	Voltage Adjust Rheostat
DSE9470 10A Battery Charger	Automatic Transfer Switch

## ▶ OPTIONAL UL142 SUB BASE TANK

	24 hr	48 hr	72 hr
Fuel Capacity (gal)	6200		
Dimensions (L/W/H) in			
Weight lb			



**IGSA CORP.**  
5918 Santa Ave  
Laredo, Texas 78041  
Tel. +1 956.7914.472

[www.igsapower.com](http://www.igsapower.com)

	Model :	<b>16M55G8D2/6</b>	Date :	30/11/22
	<b>PowerKit Engine Datasheet</b>		Page :	1 / 4

## Ratings

RPM	Gross Engine Output				Net Engine Output			
	PRP		ESP		PRP		ESP	
	kWm	BHP	kWm	BHP	kWm	BHP	kWm	BHP
1800	3300 *	4425 *	3600	4828	\ *	\ *	\	\

1 kWm = 1,34102 BHP

When the engine is used with a cooling system using an electrically driven fan, net engine output data may change and quoted figures should be used for reference only

## Basic data

Engine model	16M55G8D2/6
N° of Cylinders / Valves	16 / 64
Cylinders arrangement	At Vee
Bore x Stroke (mm)	180 x 215
Displacement (L)	87.5
Thermodynamic Cycle	Diesel 4 stroke
Firing Order	A1-B1-A3-B3-A2-B2-A5-B5-A8-B8-A6-B6-A7-B7-A4-B4
Mean Piston Speed (m/s)	12.9
BMEP @ ESP (Bar)	27.43
Cooling System	Liquid (water + 50% antifreeze)
Injection System	Direct
Fuel System	High Pressure Common Rail
Aspiration	Turbocharged and Aftercooled
Compression ratio	16.5 : 1
Flywheel housing	SAE 00
Flywheel	21"
Rotation Viewed from Flywheel...	Counterclockwise
Allowed static bending moment of the flywheel housing...../	
N° of teeth on flywheel ring gear	202
Inertia of flywheel (kg•m <sup>2</sup> )	20.78
Inertia of crankshaft (kg•m <sup>2</sup> )	17.1
Emission standard	EPA Tier2
Overall Dimensions without radiator (Length x Width x Height) (mm)	4161x1953x2468
Engine dry weight without radiator and without radiator pipes (kg)	11500
Engine dry weight with radiator and radiator pipes (kg)	N/A
Engine wet weight with radiator (includes oil, coolant) (kg)	N/A

\* The indicated PRP Power is for reference only. This engine is designed for emergency standby power (ESP) applications only.

DPK-TDS-EN-16M55-9008-22-11-30 Moteurs Baudouin reserve the right to modify these specifications, without notice. Document not contractual.



	Model :	<b>16M55G8D2/6</b>	Date :	30/11/22
	<b>PowerKit Engine Datasheet</b>		Page :	2 / 4

### Air intake system

Air intake temperature rise (°C) .....	≤ 5
Air intake restriction clean filter (mBar) .....	≤ 35
Air intake restriction dirty filter (mBar) .....	≤ 70
Recommended air flow @ PRP (m <sup>3</sup> /min) .....	249.3
Recommended air flow @ ESP (m <sup>3</sup> /min) .....	258.5
Min. diameter of intake pipe (mm) .....	140

### Aftercooling system

Aftercooler system type .....	Air to Water
Max. intake temperature @ 25°C ambient temperature (°C) .....	55
Max. difference between intake temperature and ambient temperature (°C) .....	30
Max. intake pressure drop of aftercooler (mBar) .....	60

### Lubrication system

Oil capacity Low / High (L) .....	405 / 500
Oil pressure in normal condition idle speed (Bar) .....	≥ 1.8
Oil pressure in normal condition at 1800 Rpm @ PRP (Bar) .....	4 - 6.5
Lowest oil pressure alarm (shutdown) (Bar) .....	1.8
High Oil Pressure Warning .....	6.5
Max. oil temperature (°C) .....	105
Oil flow at 1800 Rpm (L/min) .....	1460
Oil fuel consumption ratio based on engine fuel consumption data .....	≤ 0.4g/kW·h
Total system capacity (including filters) (L) .....	582

### Heat balance test data (with ambient temperature 25 °C)

Total heat dissipation @ ESP (kJ/s) .....	5467
- Heat Rejection to Jacket Water @ ESP (kJ/s) .....	1376
- Heat Rejection to Low temperature circuit @ ESP (kJ/s) .....	861
- Radiated Heat to Ambient @ ESP (kJ/s) .....	358
- Heat Rejected to Exhaust @ ESP (kJ/s) .....	2872

### Exhaust system

Max. exhaust back pressure (mBar) .....	150
Max. exhaust temperature before turbocharger (°C) .....	740
Max. exhaust temperature after turbocharger (°C) .....	550
Exhaust flow @ PRP (m <sup>3</sup> /min) .....	832.1
Exhaust flow @ ESP (m <sup>3</sup> /min) .....	861.4
Min. diameter of exhaust pipe (mm) .....	280
Max. bending moment of exhaust gas exit flange (Nm) .....	10

	Model :	<b>16M55G8D2/6</b>	Date :	30/11/22
	<b>PowerKit Engine Datasheet</b>		Page :	3 / 4

### Cooling system without radiator

System designed for ambient temperature up to (°C) <sup>1</sup> .....	\
Radiator type .....	\
Fan type .....	\
Min. inside diameter of coolant outlet pipe (mm) .....	LT 76 / HT 96
Coolant capacity of radiator and pipes (L) .....	\
Coolant alarm (shutdown) temperature (°C) .....	112
Thermostat opening temperature / full open temperature (°C) .....	82 / 92
Max. additional restriction for external cooling circuit (Bar) .....	HT 0.6 / LT 0.4
Coolant capacity of the engine (L) .....	350.5
Cooling fan airflow (m <sup>3</sup> /min)* .....	\
Fan absorbed power (kW) .....	\
Additional restriction (for reference) - Duct allowance (Pa) .....	150

\* Air flow figure assumes the presence of the standard radiator provided, taking into consideration the backpressure caused

### Fuel system

Governor .....	ECU
Governor steady state speed stability at constant load (ISO 8528-5 Class G3) <sup>2</sup> .....	≤ +/- 0.5 %
Max. restriction at fuel inlet (Bar) .....	0.1
Max. pressure at fuel inlet (Bar) .....	0.5
Max. fuel return restriction (Bar) .....	0.2
Max. fuel inlet temperature (°C) .....	70
Fuel supply flow (L/hr) .....	3400
Min. internal diameter of inlet pipe (mm) .....	19
Min. internal diameter of return pipe (mm) .....	19

### Electrical system

Electrical system voltage (negative to ground) (Vdc) .....	24
Starter power (kW) .....	2 x 10
Battery charger current (A) .....	55
Battery charger absorbed power (kW) .....	1.6
Max. electric resistance of starting circuit (Ω) .....	0.008
Min. sectional area of wire (mm <sup>2</sup> ) .....	2 x 95
Min. cold start temperature without auxiliary starting device (°C) <sup>3</sup> .....	-10
Min. cold start temperature with auxiliary starting device (°C) <sup>3</sup> .....	TBA

<sup>1</sup> The indicated value is based on the AOT value of 1°C for an engine tested at 100% of the ESP Power, reflecting temperature in an open condition, without an enclosure or container, without any airflow obstruction in the front of the radiator, without air recirculation, with free exhaust gas exit and with the engine thermostatic valve in its full open condition, without a closing plate present. The reference air restriction is equal to 50Pa. For the equivalent ATB (Air-to-Boil) performance in a customer or project basis, please consult Baudouin Application Engineering.

<sup>2</sup> This refers only to the frequency response of the engine and should not be confused with the performance class of the Generator Set, which is subject to additional contributing factors such as alternator selection and control settings.

<sup>3</sup> Engines used in emergency standby application or applications that require immediate start under load, they must be equipped with coolant heaters. Baudouin recommend heaters installation to be executed by providing constant coolant circulation across all the engine components. Two heaters are required for V-type engines, one per each side.

	Model : <b>16M55G8D2/6</b>	Date : 30/11/22
	<b>PowerKit Engine Datasheet</b>	Page : 4 / 4

## Noise

Diesel engine noise (Acoustic power level) (dB(A)) .....	127.3
Noise - upper side (dB(A)) .....	110.2
Noise - right side (view from flywheel) (dB(A)) .....	108.0
Noise - left side (view from flywheel) (dB(A)) .....	110.7
Noise – front (radiator) side (dB(A)) .....	105.6
Noise – rear (flywheel) side (dB(A)) .....	105.8

### Notes :

- Noise test made at 100% of the ESP power, at 1 mt. distance, on engine without radiator, without cooling fan and without silencer.
- Noise test refers to ISO 6798 norm : “Reciprocating internal combustion engines. Measurement of emitted airborne noise. Engineering method and survey method”.

## Fuel consumption

Rating	gr/kWh	L/hr
100% ESP	206.8	887.5
100% PRP	212.5	834.6
75% PRP	222.8	656.5
50% PRP	233.3	458.3
25% PRP	269.7	264.9
Fuel consumption tolerance +/- 5%		

### Notes:

This engine is designed for ESP (Emergency Standby) applications only, the values shown above at PRP levels refer to the Referenced Power ( 3300 kWm).

## Ratings definitions

### Emergency Standby Power (ESP)

Emergency Standby Power is the maximum power available for a varying load for the duration of a main power network failure. The average load factor over 24 hours of operation should not exceed 70% of the engine’s ESP power rating. Typical operational hours of the engine is 200 hours per year, with a maximum usage of 500 hours per year. This includes an annual maximum of 25 hours per year at the ESP power rating. No overload capability is allowed. The engine is not to be used for sustained utility paralleling applications.

### Prime Power (PRP)

Prime Power is the maximum power available for unlimited hours of usage in a variable load application. The average load factor should not exceed 70% of the engine’s PRP power rating during any 24 hour period. An overload capability of 10% is available, however, this is limited to 1 hour within every 12 hour period.

- All ratings are based on operating conditions under ISO 8528-1, ISO 3046, DIN6271. Performance tolerance of  $\pm 5\%$ .
- Test conditions : 100 kPa, 25°C air inlet temperature, relative humidity of 30%, with fuel density 0.84 kg/L. Derating may be required for conditions outside these; please contact the factory for details.
- Power output curves are based on the engine operating with fuel system, water pump and lubricating oil pump; not included are battery charging alternator, fan and optional equipment.

# STAMFORD® | AvK®

## LV 804 W WDG 07 - Technical Data Sheet

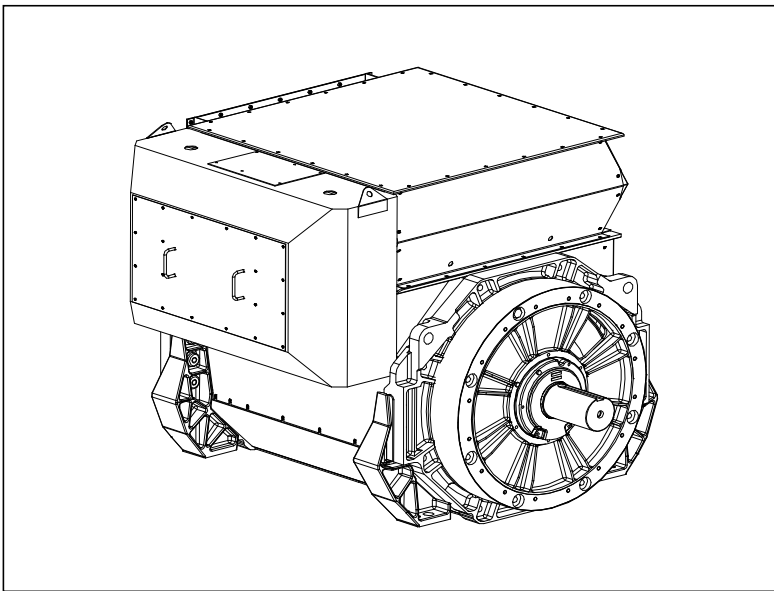

# FRAME LV 804 W

## SPECIFICATIONS & OPTIONS

**STAMFORD | AvK**

### STANDARDS

Cummins Generator Technologies industrial generators meet the requirements of BS EN 60034 and the relevant sections of other national and international standards such as BS5000, VDE 0530, NEMA MG1-32, IEC60034, CSA C22.2-100, AS1359. Other standards and certifications can be considered on request.

### DESCRIPTION

The STAMFORD PI range of synchronous ac generators are brushless with a rotating field. They are separately excited by the STAMFORD Permanent Magnet Generator (PMG). This is a shaft mounted, high frequency, pilot exciter which provides a constant supply of clean power via the Automatic Voltage Regulator (AVR) to the main exciter. The main exciter output is fed to the main rotor, through a full wave bridge rectifier, protected by surge suppression.

### VOLTAGE REGULATORS

The P80 range generators complete with a PMG are available with one AVR. Underspeed protection (UFRO) is also provided by the AVR. The UFRO will reduce the generator output voltage proportional to the speed of the generator below a pre-settable level.

The STAMFORD | AvK Digital Excitation Control System (DM110) is an electronic, solid-state, microprocessor based control device. The DM110 regulates the output voltage of a the ac generator by controlling the current into the generator exciter field. Input power to the DM110 is provided by a multi-pole, high-frequency, permanent magnet generator (PMG).

The DM110 is supplied in an encapsulated package designed for behind-the-panel mounting. Front panel indicators (LEDs) annunciate DM110 status and system conditions. DM110 connections are made through quarterinch, quick-connect terminals on the rear panel. A 9-pin DB-9 type connector on the rear panel provides communication between the DM110 and an IBM compatible PC.

Technical details on the DM110 are available on the Stamford-AvK website using the following URL:  
<https://www.stamford-avk.com/downloads/avr-manuals>

### WINDINGS & ELECTRICAL PERFORMANCE

All generator stators are wound to 2/3 pitch. This eliminates triplen (3rd, 9th, 15th ...) harmonics on the voltage waveform and is found to be the optimum design for trouble-free supply of non-linear loads. The 2/3 pitch design avoids excessive neutral currents sometimes seen with higher winding pitches. A fully connected damper winding reduces oscillations during paralleling. This winding, with the 2/3 pitch and carefully selected pole and tooth designs, ensures very low levels of voltage waveform distortion.

### TERMINALS & TERMINAL BOX

Standard generators feature a main stator with 6 ends brought out to the terminals, which are mounted on the frame at the non-drive end of the generator. A sheet steel terminal box contains the AVR and provides ample space for the customers' wiring and gland arrangements. It has removable panels for easy access.

### SHAFT & KEYS

All generator rotors are dynamically balanced to better than BS6861:Part 1 Grade 2.5 for minimum vibration in operation. Two bearing generators are balanced with a half key.

### INSULATION/IMPREGNATION

The insulation system is class 'H'. All wound components are impregnated with materials and processes designed specifically to provide the high build required for static windings and the high mechanical strength required for rotating components.

### QUALITY ASSURANCE

Generators are manufactured using production procedures having a quality assurance level to BS EN ISO 9001.

### NOTE ON REGULATION

The stated voltage regulation may not be maintained in the presence of certain radio transmitted signals. Any change in performance will fall within the limits of Criteria 'B' of EN 61000-6-2:2001. At no time will the steady-state voltage regulation exceed 2%.

NB Continuous development of our products entitles us to change specification details without notice, therefore they must not be regarded as binding.

Front cover drawing is typical of the product range.

# FRAME LV 804 W WINDING 07

**STAMFORD | AvK**

RATINGS	REFER TO SALES AND SERVICE BRIEFING
MAXIMUM ALTITUDE	1000 METRES ABOVE SEA LEVEL
MAXIMUM AMBIENT TEMPERATURE	40° C

CONTROL SYSTEM SERIES 3	SEPARATELY EXCITED BY P.M.G.
A.V.R.	FULL WAVE RECTIFIED
VOLTAGE REGULATION	± 0.25%
SUSTAINED SHORT CIRCUIT	REFER TO SHORT CIRCUIT DECREMENT CURVES OF THIS SECTION

INSULATION SYSTEM	CLASS H
PROTECTION	IP23 STANDARD
RATED POWER FACTOR	0.8
STATOR WINDING	DOUBLE LAYER LAP
WINDING PITCH	2/3
WINDING LEADS	6
R.F.I. SUPPRESSION	BS EN 50081/2-1/2 VDE 0875G VDE 0875N For other standards apply to the factory
WAVEFORM DISTORTION	NO LOAD < 1.5% NON-DISTORTING BALANCED LINEAR LOAD < 3.0%
MAXIMUM OVERSPEED	2250 Rev/Min
BEARING DRIVE END	ISO 6236 C3
BEARING NON DRIVE END	ISO 6324 C3
EFFICIENCY	REFER TO EFFICIENCY CURVES OF THIS SECTION

FREQUENCY	60Hz
TELEPHONE INTERFERENCE	TIF < 50
COOLING AIR	4.5 m <sup>3</sup> /sec
VOLTAGE STAR (Y)	600
kVA BASE RATING FOR REACTANCE VALUES	4142
X <sub>d</sub> DIRECT AXIS SYNCHRONOUS	2.300
X' <sub>d</sub> DIRECT AXIS TRANSIENT	0.167
X'' <sub>d</sub> DIRECT AXIS SUB-TRANSIENT	0.122
X <sub>q</sub> QUADRATURE AXIS REACTANCE	1.600
X' <sub>q</sub> QUAD. AXIS SUB-TRANSIENT	0.228
X <sub>L</sub> LEAKAGE REACTANCE	0.070
X <sub>2</sub> NEGATIVE PHASE SEQUENCE	0.175
X <sub>0</sub> ZERO PHASE SEQUENCE	0.024

REACTANCES ARE SATURATED	VALUES ARE PER UNIT AT RATING AND VOLTAGE INDICATED
T' <sub>d</sub> TRANSIENT TIME CONSTANT	0.209
T'' <sub>d</sub> SUB-TRANSIENT TIME CONSTANT	0.016
T' <sub>do</sub> O.C. FIELD TIME CONSTANT	5.060
T <sub>a</sub> ARMATURE TIME CONSTANT	0.077
SHORT CIRCUIT RATIO	1/X <sub>d</sub>

STATOR WINDING RESISTANCE (L-N)	0.000479
ROTOR WINDING RESISTANCE	1.470
EXCITER STATOR FIELD RESISTANCE	17.00
EXCITER ROTOR RESISTANCE (L-L)	0.092
PMG STATOR RESISTANCE (L-L)	3.800
RESISTANCE VALUES ARE IN OHMS AT 20° C	

NO LOAD EXCITATION VOLTAGE	15.0
FULL LOAD EXCITATION VOLTAGE	67.0

Continuous development of our products entitles us to change specification details without notice, therefore they must not be regarded as binding.

THREE PHASE EFFICIENCY CURVES

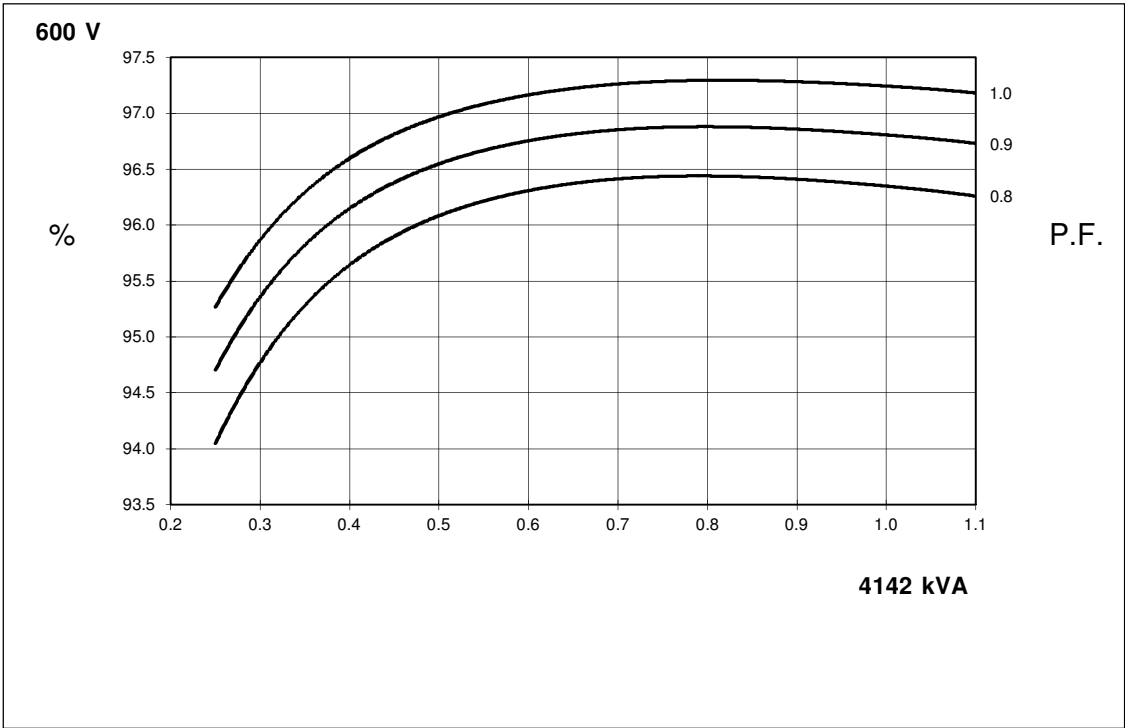

FULL WAVE RECTIFIED AVR  
 LOCKED ROTOR MOTOR STARTING CURVE

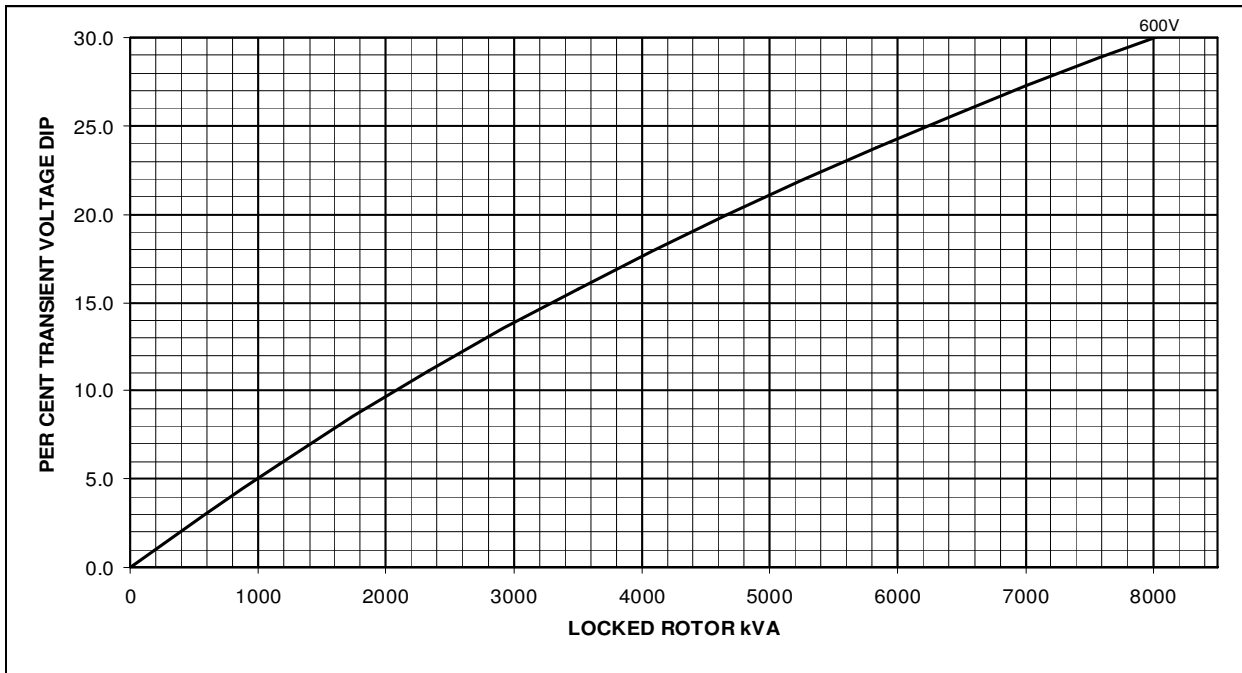

FRAME LV 804 W WDG 07 60Hz

Three Phase Short Circuit Decrement Curve  
 No- Load Excitation at Rated Speed

Based on series star (wye) connection

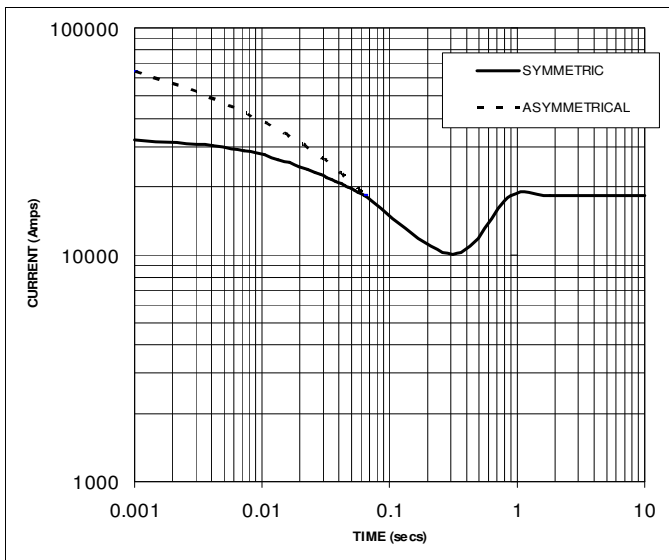

NOTE 1

THE FOLLOWING MULTIPLICATION FACTORS SHOULD BE USED TO ADJUST THE VALUES FROM CURVES BETWEEN THE 0.001 SECONDS AND THE MINIMUM CURRENT POINT IN RESPECT OF NOMINAL OPERATING VOLTAGE

VOLTAGE	FACTOR
600V	X 1.00

THE SUSTAINED CURRENT VALUE IS CONSTANT IRRESPECTIVE OF VOLTAGE LEVEL

NOTE 2

THE FOLLOWING MULTIPLICATION FACTORS SHOULD BE USED TO CONVERT THE VALUES CALCULATED IN ACCORDANCE WITH NOTE 1 TO THOSE APPLICABLE TO THE VARIOUS TYPES OF SHORT CIRCUIT

	3 PHASE	2 PHASE L-L	1 PHASE L-N
INSTANTANEOUS	X 1.0	X 0.87	X 1.30
MINIMUM	X 1.0	X 1.80	X 3.20
SUSTAINED	X 1.0	X 1.50	X 2.50
MAX SUSTAINED DURATION	10 SEC	5 SEC	2 SEC

ALL OTHER TIMES ARE UNCHANGED

SUSTAINED SHORT CIRCUIT = 18334 Amps



# FRAME LV 804 W

## WINDING 07     0.8 Power Factor

### RATINGS

**STAMFORD | AvK**

Class - Temp Rise	Cont. F - 105/40°C	Cont. H - 125/40°C	Standby - 150/40°C	Standby - 163/27°C
<b>50Hz</b> Star (V)	N/A	N/A	N/A	N/A
kVA	N/A	N/A	N/A	N/A
kW	N/A	N/A	N/A	N/A
Efficiency (%)	N/A	N/A	N/A	N/A
kW Input	N/A	N/A	N/A	N/A
<b>60Hz</b> Star (V)	600	600	600	600
kVA	3871	4142	4430	4550
kW	3097	3314	3544	3640
Efficiency (%)	96.4	96.3	96.3	96.3
kW Input	3214	3439	3681	3781

**TYPICAL DIMENSIONS - Further arrangements available - please refer to factory**

P80 R/S/T CORES

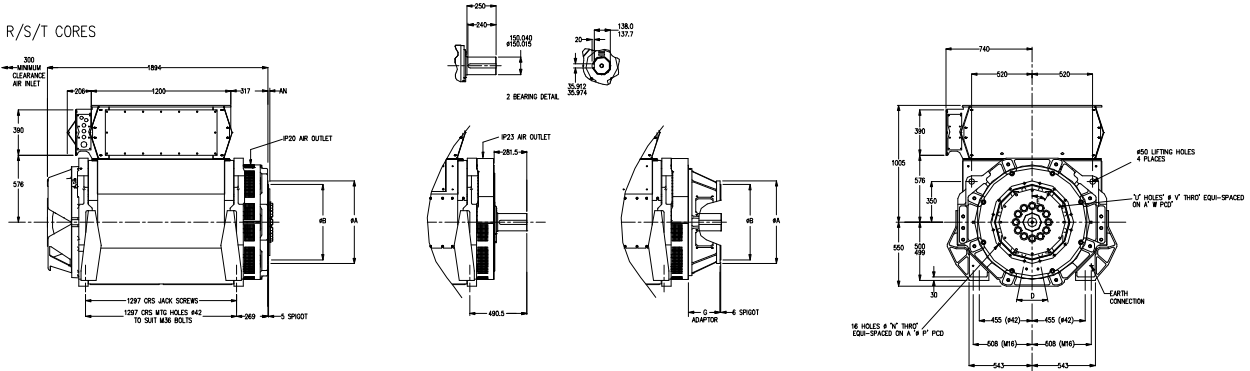

P80 R/S/T CORES					
1-BRG ADAPTORS					
SAE	A	B	N	P	D
SAE 0	711	647.7	14	679.5	22.5"
SAE 00	883	787.4	14	851.0	22.5"

P80 R/S/T/W/X CORES						
1-BRG COUPLING DISC						
SAE	AN	C	U	V	W	E
1R	15.9	571.4	12	16.7	543.0	30"
21	0	673.0	12	16.7	641.3	30"
24	0	733.3	12	20.7	692.0	30"

P80 R/S/T/W/X CORES		
2-BRG ADAPTORS		
SAE	G	
P80 R/S/T	0	271.5
P80 R/S/T	00	271.5
P80 W/X	0	271.5
P80 W/X	00	529.0

P80 R/S/T/W/X CORES					
2-BRG ADAPTORS					
SAE	A	B	N	P	D
SAE 0	711	647.7	14	679.5	22.5"
SAE 00	883	787.4	14	851.0	22.5"

P80 W/X CORES

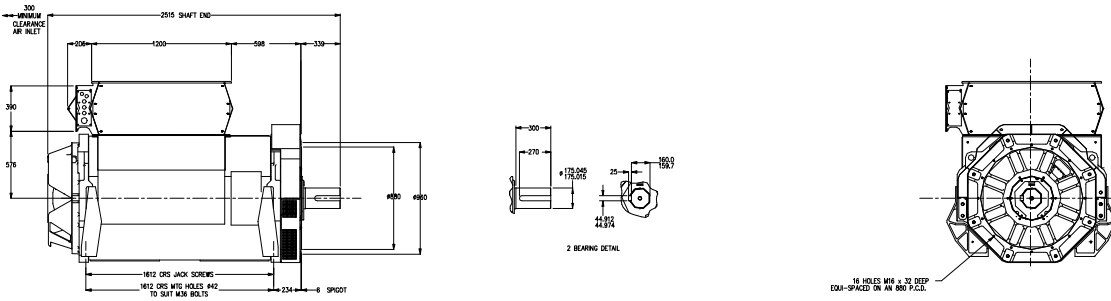

**STAMFORD | AvK**

**SIMBOLGY CONTROL**  
 —( )— INSPECTION DIMENSION  
 (No.) DRAWING REVISION

\*NOTE: LOCATIONS OF COOLANT HEATER AND BATTERIES ARE DIFFERENT FOR EACH ENGINE MODEL

NON SPECIFIED TOLERANCES			
PART TOLERANCES TABLE		GENERAL TOLERANCES	
INTERVAL	TOLERANCE	DIAMETERS	ANGULAR
0" - 40"	± 0.04"	± 0.02"	± 2°
40" - 16.5"	± 0.08"		
16.5" - 40"	± 0.12"	± 0.36" ± 0.002"	
40" - 328"	± 0.14"		
MATERIAL	ITEM	WEIGHT (kg)	FINISH
CARBON STEEL SHEET METAL 1.9 mm THICKNESS		NA	CLEAN SURFACES FREE OF BURRS

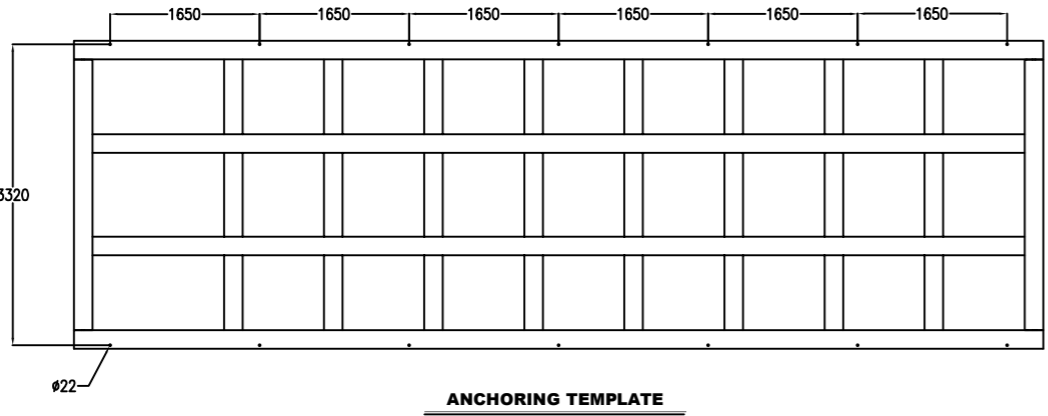
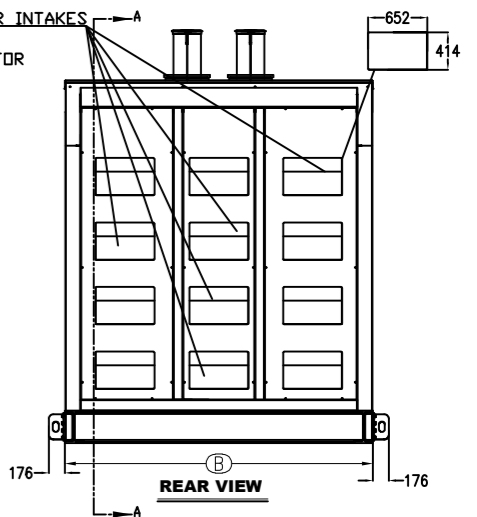
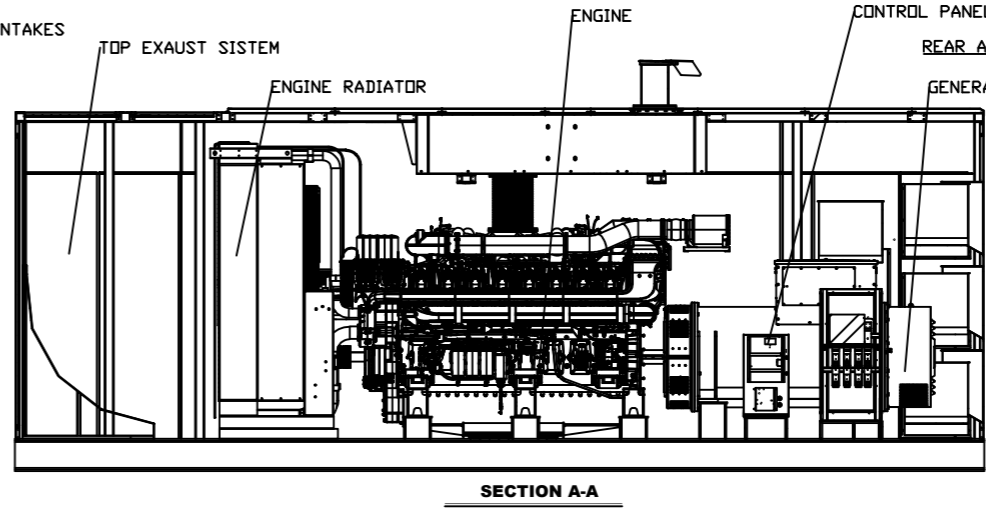
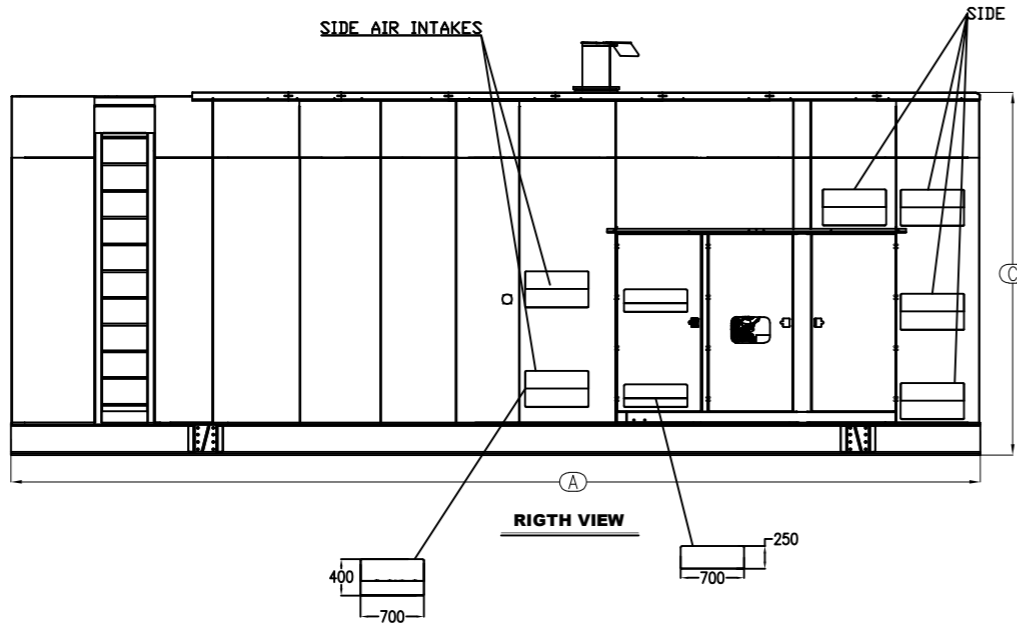
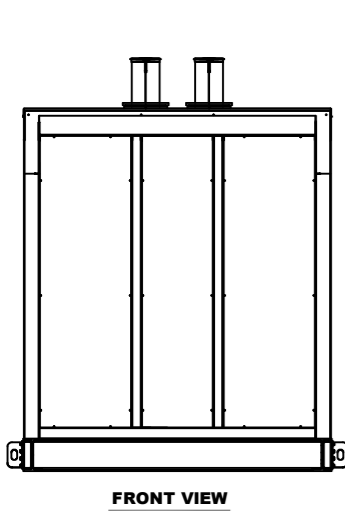
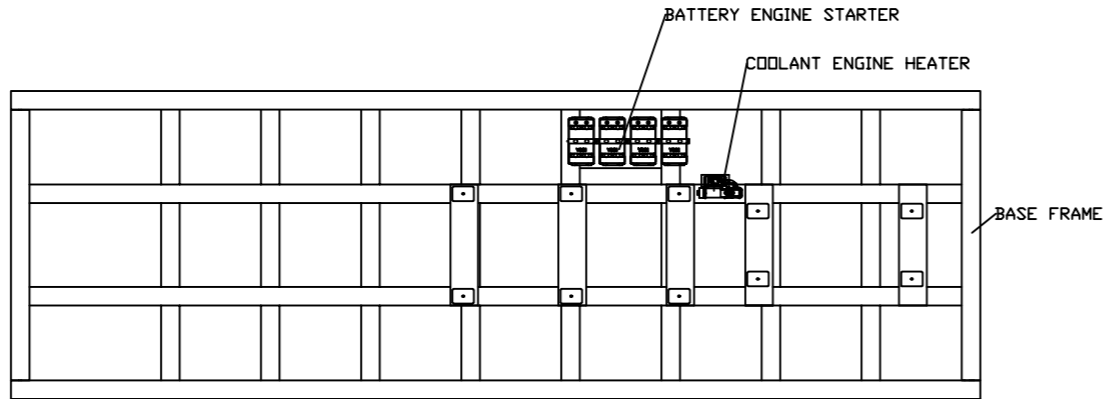

OVERALL DIMENSIONS TABLE OF ACOUSTIC CABIN		
	MINIMUM SIZE	MAXIMUM SIZE
A (LENGTH)	10700	11200
B (WIDE)	3400	3900
C (HIGH)	4000	4500

DEPT.: ENGINEERING	DATE: 07-08-2023	DRAWING: MBG	REVISED: OLM	APPROVED: RMD
SCALE: SIN. ACOT.: mm	CUSTOMER: UL CERTIFICATION	DRAWING No.: PDE 2640-3300 KW BAUDOUIN ENGINE	REV.: 00	SHEET 1 OF 1
TITLE: CHASSIS AND ACOUSTIC CABIN FOR 2640-3300 KW BAUDOUIN ENGINE				
IGSA S.A. DE C.V. <small>OFFICE GENERAL: RIDE DE REFORM No. 2977, COL. CUADRALPA, CP 05000, CIUDAD DE MEXICO, MEX. PLANT: ANIMULULCO-DECIYACAC KM-5 ROAD, LERMA EDO. FROM MEXICO, CP 52740. ENGINEERING DEPARTMENT: TEL: 01 55 56263350 Ext: 3018, 3029 &amp; 3036.</small>		HE INFORMATION CONTAINED HEREIN IS EXCLUSIVE PROPERTY IGSA S.A. DE C.V. THEREFORE IT CAN NOT BE USED, COPIED OR DUPLICATED WITHOUT THE WRITTEN CONSENT IGSA S.A. DE C.V.		

SIMBOLY CONTROL  
 —|— INSPECTION DIMENSION  
 No. DRAWING REVISION

NON SPECIFIED TOLERANCES			
PART TOLERANCES TABLE		GENERAL TOLERANCES	
INTERVAL	TOLERANCE	DIMETERS	ANGULAR
0" - 40"	± 0.04"	±0.03"	± 2°
40" - 16.5"	± 0.08"		
16.5" - 40"	± 0.12"	0.36" ± 0.002	
40" - 328"	± 0.4"		
MATERIAL		ITEM	WEIGHT (kg)
CARBON STEEL SHEET METAL 19 mm THICKNESS			NA
FINISH CLEAN SURFACES FREE OF BURRS			

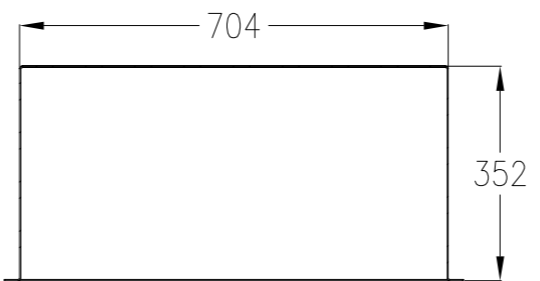
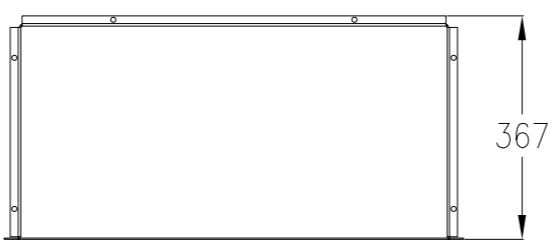
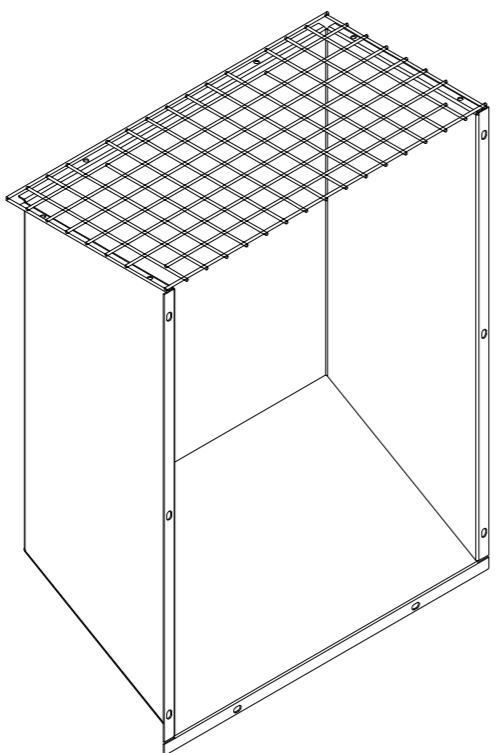

SECCIÓN A-A

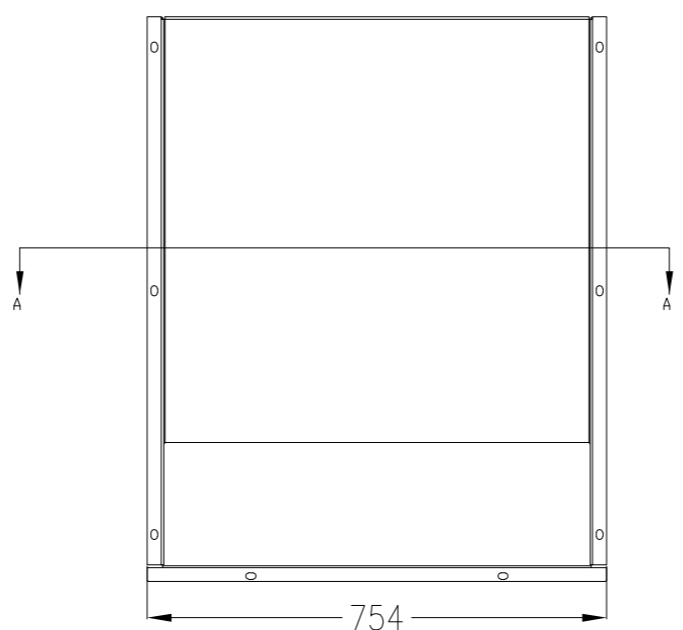
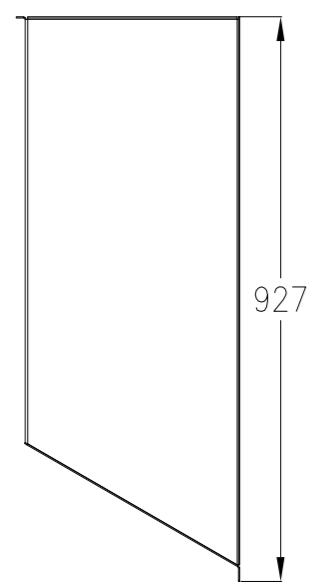
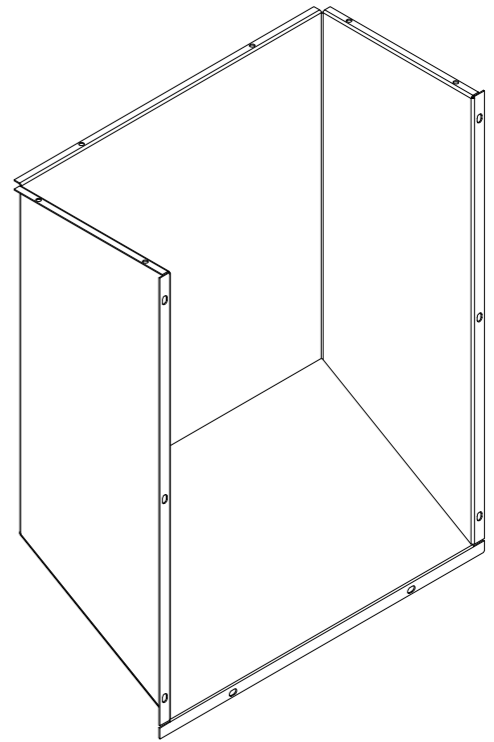

DEPT.: ENGINEERING	DATE: 07-08-2023	DRAWING: MBG	REVISED: DLM	APPROVED: RMD
SCALE: SIN / ACOT: INCH	CUSTOMER: UL CERTIFICATION	DRAWING No.: 502296-51		REV: 00
TITLE: AIR INTAKE SIDE BAFFLE ASSEMBLY				SHEET 1 OF 1
IGSA S.A. DE C.V. <small>OFFICE GENERAL: RIDE OF REFORM No. 2977, COL. CUAJIMALPA, CP 05000, CDMX, MEX.          PLANT: AMOMULULCUI-DCIYDZAC KM-S ROAD, LERMA EDO. FROM MEXICO, CP 52740          ENGINEERING DEPARTMENT- TEL: 01 (52) 5685359 Ex: 3018,3029 &amp; 3030.</small>		HE INFORMATION CONTAINED HEREIN IS EXCLUSIVE PROPERTY IGSA S.A. DE C.V. THEREFORE IT CAN NOT BE USED, COPIED OR DUPLICATED WITHOUT THE WRITTEN CONSENT IGSA S.A. DE C.V.		



SIMBOLGY CONTROL	
	INSPECTION DIMENSION
	DRAWING REVISION

PART TOLERANCES TABLE				NON SPECIFIED TOLERANCES	
INTERVAL	TOLERANCE	GENERAL TOLERANCES			
		DIAMETERS	ANGULAR		
0" - 40"	± 0.04"	± 0.03"	± 2°		
40" - 16.5'	± 0.08"				
16.5' - 40'	± 0.12"	± 0.36" ± 0.002"			
40' - 328'	± 0.4"				
MATERIAL	ITEM	WEIGHT (kg)	FINISH		
CARBON STEEL SHEET METAL 1.9 mm THICKNESS		NA	CLEAN SURFACES FREE OF BURRS		

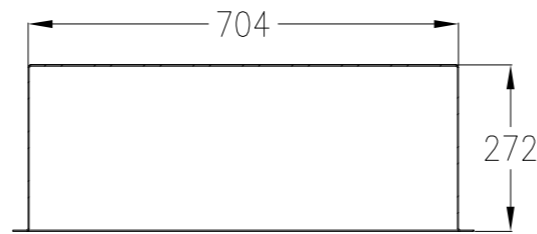
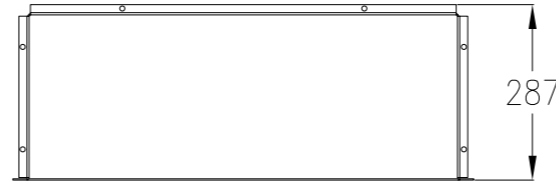
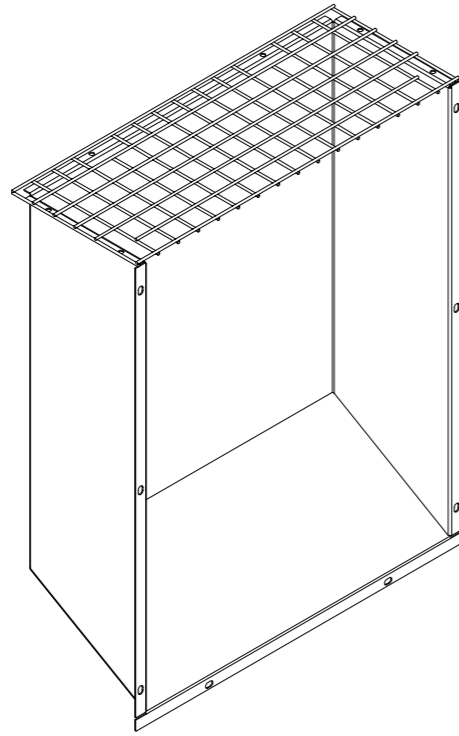

SECCION A-A

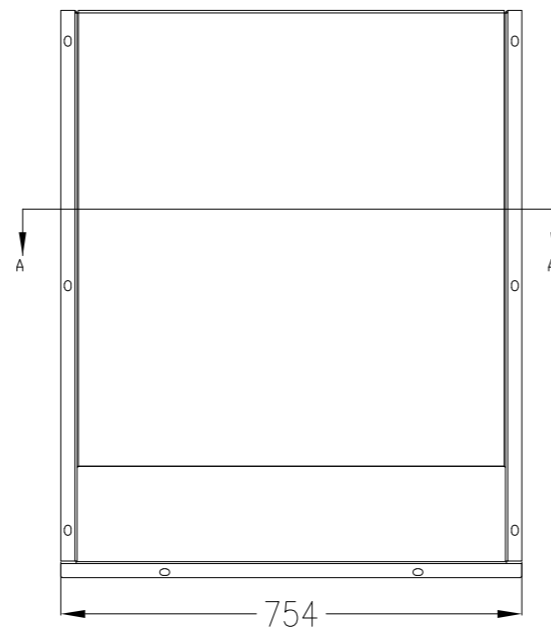
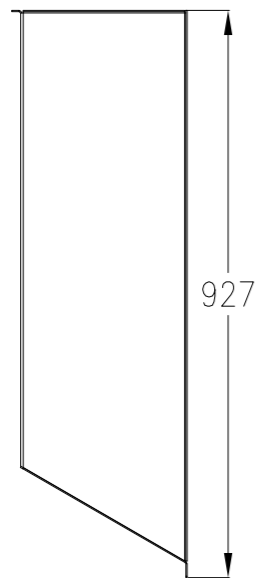
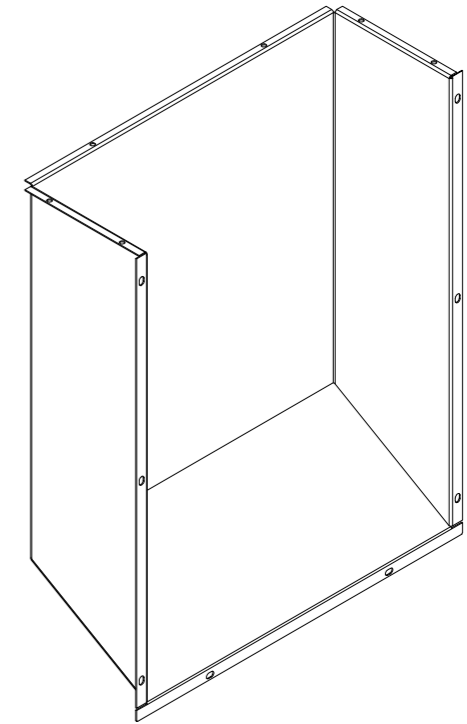

DEPT.: ENGINEERING	DATE: 07-08-2023	DRAWING: MBG	REVISED: OLM	APPROVED: RMD
SCALE: SIN / ACOT.: INCH	CUSTOMER: UL CERTIFICATION	DRAWING No.: 502296-55		REV.: 00
TITLE: AIR INTAKE SIDE BAFFLE ASSEMBLY				SHEET 1 OF 1
IGSA S.A. DE C.V. <small>OFFICE GENERAL: RIDE OF REFORM No. 2977, COL. CUAJIMALPA, CP 05000, CIJAX, MEX.          PLANT: AVENIDA LUCO-BOYDORACAS KM-5 ROAD, LERMA EDO. FROM MEXICO, CP 32740          ENGINEERING DEPARTMENT: TEL: 01 (52) 56255250 Ext: 3018,3020 &amp; 3030.</small>		THE INFORMATION CONTAINED HEREIN IS EXCLUSIVE PROPERTY IGSA S.A. DE C.V. THEREFORE IT CAN NOT BE USED, COPIED OR DUPLICATED WITHOUT THE WRITTEN CONSENT IGSA S.A. DE C.V.		

**SIMBOLOGY CONTROL**  
 —( )— INSPECTION DIMENSION  
 (No.) DRAWING REVISION

NON SPECIFIED TOLERANCES			
PART TOLERANCES TABLE		GENERAL TOLERANCES	
INTERVAL	TOLERANCE	DIAMETERS	ANGULAR
0" - 40"	± 0.04"	± 0.03"	± 2°
40" - 16.5"	± 0.08"		
16.5" - 40"	± 0.12"	± 0.06"	
40" - 320"	± 0.14"		
MATERIAL		ITEM	WEIGHT (kg)
CARBON STEEL SHEET METAL 1.9 mm THICKNESS			NA
		FINISH	
		CLEAN SURFACES FREE OF BURRS	

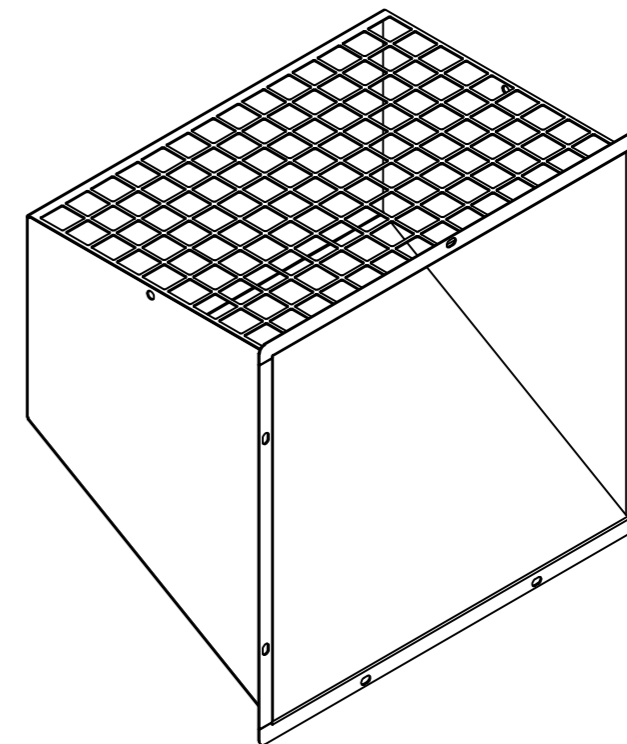
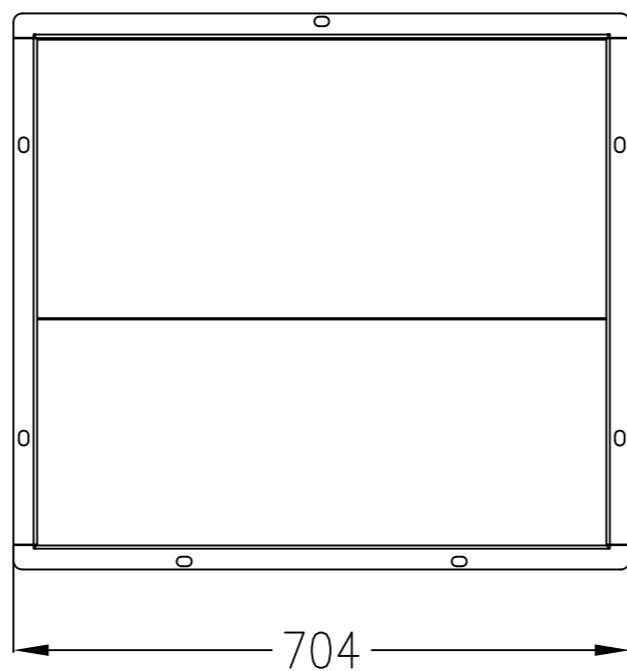
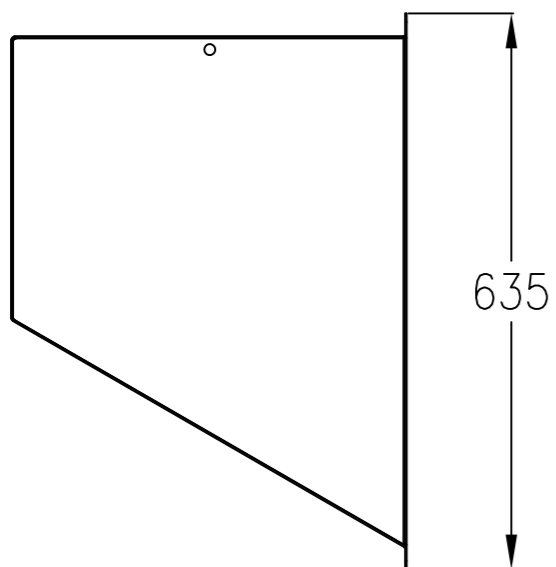
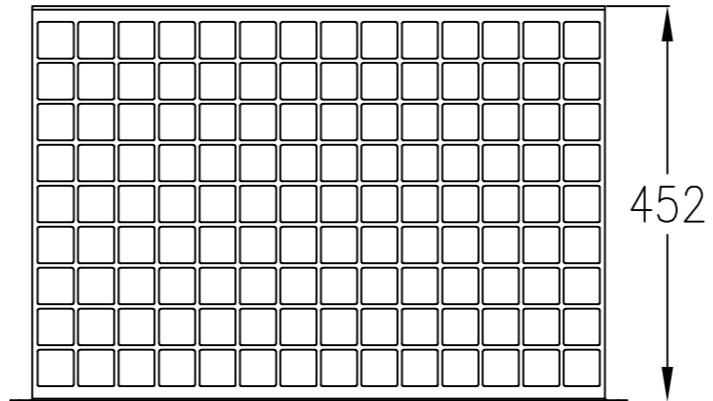

DEPT: ENGINEERING	DATE: 07-08-2023	DRAWING: MBG	REVISED: OLM	APPROVED: RMD
SCALE: SIN / ACOT: INCH	CUSTOMER: UL CERTIFICATION	DRAWING No: 502427-58		
TITLE: AIR INTAKE REAR Baffle ASSEMBLY				REV: 00
				SHEET 1 OF 1
IGSA S.A. DE C.V. <small>OFFICE GENERAL: RDE OF REFORM No. 2977, COL. CUADRALPA, CP 05000, CIUDAD DE MEXICO, MEX.          PLANTA: ANONILULCO-OCOTYDACA 10-S ROAD, LERMA EXD. FROM MEXICO, CP 52740          ENGINEERING DEPARTMENT: TEL: 01 52 56263350 Ext: 3016,3020 &amp; 3030.</small>		HE INFORMATION CONTAINED HEREIN IS EXCLUSIVE PROPERTY IGSA S.A. DE C.V. THEREFORE IT CAN NOT BE USED, COPIED OR DUPLICATED WITHOUT THE WRITTEN CONSENT IGSA S.A. DE C.V.		

SIMBOLGY CONTROL  
 —( )— INSPECTION DIMENSION  
 No. DRAWING REVISION

NON SPECIFIED TOLERANCES			
PART TOLERANCES TABLE		GENERAL TOLERANCES	
INTERVAL	TOLERANCE	DIMETERS	ANGULAR
0" - 40"	± 0.04"	± 0.02°	± 2°
40" - 16.5"	± 0.08"		
16.5" - 40"	± 0.12"	± 0.35° ± 0.002	
40" - 328"	± 0.4"		
MATERIAL	ITEM	WEIGHT (kg)	FINISH
CARBON STEEL SHEET METAL 1.9 mm THICKNESS		NA	CLEAN SURFACES FREE OF BURRS

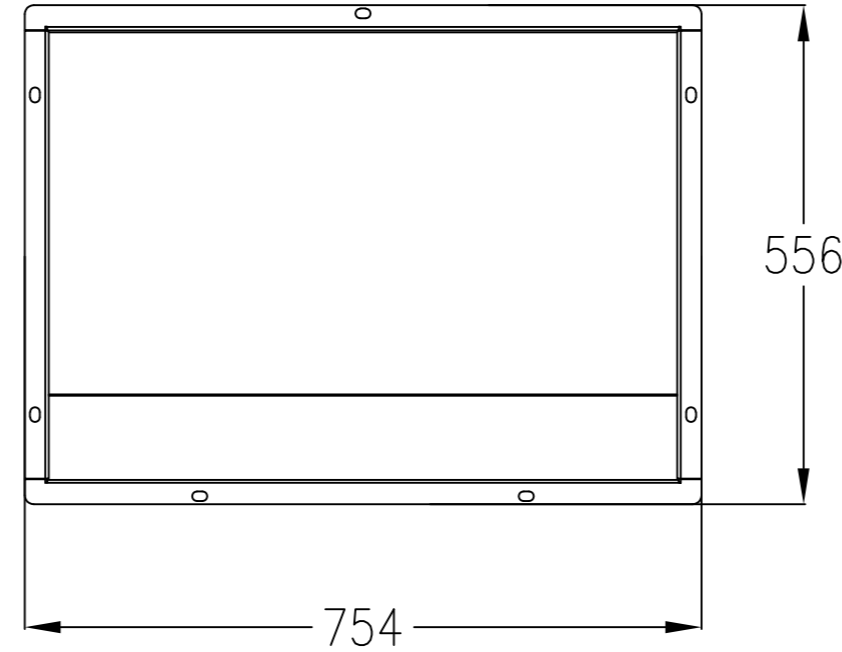
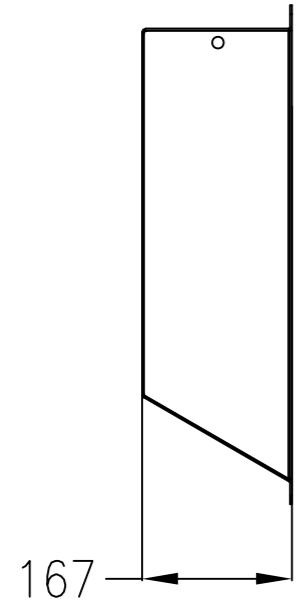
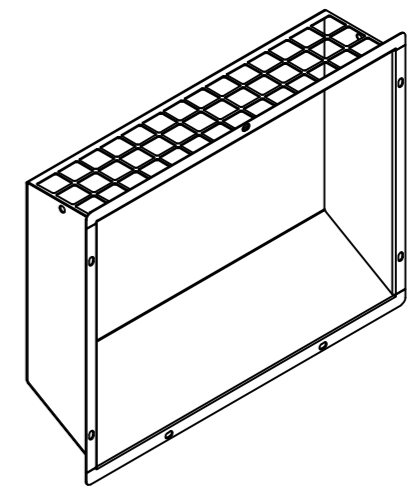
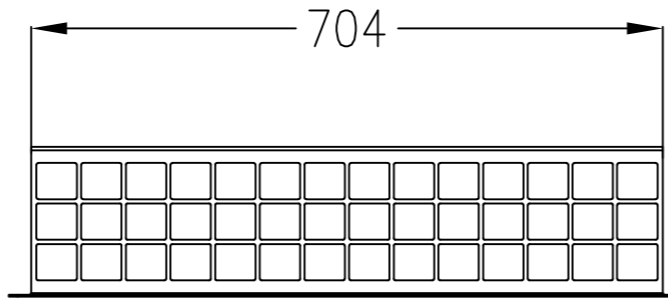

DEPT: ENGINEERING	DATE: 07-08-2023	DRAWING: MBG	REVISED: OLM	APPROVED: RMD
SCALE: SIN. ACOT: INCH	CUSTOMER: UL CERTIFICATION	DRAWING No: 502427-59		REV: 00
TITLE: AIR INTAKE SIDE BAFFLE ASSEMBLY				SHEET 1 OF 1
IGSA S.A. DE C.V. <small>OFFICE GENERAL: RIDE OF REFORM No. 2977, COL. CUAJIMALPA, CP 05000, CDMX, MEX.          PLANT: AMHOLLOLO-DOCTOMACAC KM-5 ROAD, LERMA EDO. FROM MEXICO, CP 52740          ENGINEERING DEPARTMENT: TEL: 01 (52) 56263300 Ext: 3018,3020 &amp; 3030.</small>		THE INFORMATION CONTAINED HEREIN IS EXCLUSIVE PROPERTY IGSA S.A. DE C.V. THEREFORE IT CAN NOT BE USED, COPIED OR DUPLICATED WITHOUT THE WRITTEN CONSENT IGSA S.A. DE C.V.		



# CERTIFICATE OF COMPLIANCE

**Certificate Number** UL-US-2345744-0  
**Report Reference** AU6440-20231107  
**Date** 10-Nov-2023

**Issued to:** IGSA S A DE C V  
PROLONGACION PASEO DE LA REFORMA # 2977  
COL CUAJIMALPA  
MEXICO, Mexico 05000  
Mexico

**This is to certify that representative samples of** FTSR - Engine Generators  
See Addendum Page for Product Designation(s).

Have been evaluated by UL in accordance with the Standard(s) indicated on this Certificate.

**Standard(s) for Safety:** UL 2200, 2nd Ed., Issue Date: 2012-06-01, Revision Date: 2015-07-29

**Additional Information:** See the UL Online Certifications Directory at <https://iq.ulprospector.com> for additional information

This Certificate of Compliance indicates that representative samples of the product described in the certification report have met the requirements for UL certification. It does not provide authorization to apply the UL Mark. Only the Authorization Page that references the Follow-Up Services Procedure for ongoing surveillance provides authorization to apply the UL Mark.

Only those products bearing the UL Mark should be considered as being UL Certified and covered under UL's Follow-Up Services.

Look for the UL Certification Mark on the product.

*Deborah Jennings-Conner*

Deborah Jennings-Conner, VP Regulatory Services

UL LLC

Any information and documentation involving UL Mark services are provided on behalf of UL LLC (UL) or any authorized licensee of UL. For questions, please contact a local UL Customer Service Representative at <http://ul.com/aboutul/locations/>



# CERTIFICATE OF COMPLIANCE

**Certificate Number** UL-US-2345744-0  
**Report Reference** AU6440-20231107  
**Date** 10-Nov-2023

This is to certify that representative samples of the product as specified on this certificate were tested according to the current UL requirements

<b>Model</b>	<b>Category Description</b>
GSBD00700S, GSBD00700L, GSBD00700LT GSBD00700W	Engine Generators
GSBD00800S, GSBD00800L, GSBD00800LT GSBD00800W	Engine Generators
GSBD01000S, GSBD01000L, GSBD01000W	Engine Generators
GSBD01300S, GSBD01300L, GSBD01300W	Engine Generators
GSBD01500S, GSBD01500L, GSBD01500W	Engine Generators
GSBD01700S, GSBD01700L, GSBD01700W, GSBD01750S, GSBD01750L	Engine Generators
GSBD01800S, GSBD01800L	Engine Generators
GSBD02000S, GSBD02000L	Engine Generators
GSBD02300S, GSBD02300L	Engine Generators
GSBD02500S, GSBD02500L	Engine Generators
GSBD02640S, GSBD02640L	Engine Generators
GSBD02800S, GSBD02800L	Engine Generators
GSBD03000S, GSBD03000L	Engine Generators
GSBD03300S, GSBD03300L	Engine Generators
GSBD30600S, GSBD30600L, GSBD30600LT GSBD30600W	Engine Generators
GSBD30633S, GSBD30633L, GSBD30633LT GSBD30633W	Engine Generators
GSBD30644S, GSBD30644L, GSBD30644LT GSBD30644W	Engine Generators

*Deborah Jennings-Conner*  
Deborah Jennings-Conner, VP Regulatory Services



UL LLC

Any information and documentation involving UL Mark services are provided on behalf of UL LLC (UL) or any authorized licensee of UL. For questions, please contact a local UL Customer Service Representative at <http://ul.com/aboutul/locations/>



# CERTIFICATE OF COMPLIANCE

**Certificate Number** UL-CA-2339551-0  
**Report Reference** AU6440-20231107  
**Date** 10-Nov-2023

**Issued to:** IGSA S A DE C V  
PROLONGACION PASEO DE LA REFORMA # 2977  
COL CUAJIMALPA  
MEXICO, Mexico 05000  
Mexico

**This is to certify that representative samples of** FTSR7 - Engine Generators Certified for Canada  
See Addendum Page for Product Designation(s).

Have been evaluated by UL in accordance with the Standard(s) indicated on this Certificate.

**Standard(s) for Safety:** CSA C22.2 No. 14, Edition 13, Issue Date 2018-03, Revision Date 2022-06

**Additional Information:** See the UL Online Certifications Directory at <https://iq.ulprospector.com> for additional information

This Certificate of Compliance indicates that representative samples of the product described in the certification report have met the requirements for UL certification. It does not provide authorization to apply the UL Mark. Only the Authorization Page that references the Follow-Up Services Procedure for ongoing surveillance provides authorization to apply the UL Mark.

Only those products bearing the UL Mark should be considered as being UL Certified and covered under UL's Follow-Up Services.

Look for the UL Certification Mark on the product.

  
Deborah Jennings-Conner, VP Regulatory Services

UL LLC



Any information and documentation involving UL Mark services are provided on behalf of UL LLC (UL) or any authorized licensee of UL. For questions, please contact a local UL Customer Service Representative at <http://ul.com/aboutul/locations/>

# CERTIFICATE OF COMPLIANCE

**Certificate Number** UL-CA-2339551-0  
**Report Reference** AU6440-20231107  
**Date** 10-Nov-2023

This is to certify that representative samples of the product as specified on this certificate were tested according to the current UL requirements

<b>Model</b>	<b>Category Description</b>
GSBD00700S, GSBD00700L, GSBD00700LT GSBD00700W	Engine Generators
GSBD00800S, GSBD00800L, GSBD00800LT GSBD00800W	Engine Generators
GSBD01000S, GSBD01000L, GSBD01000W	Engine Generators
GSBD01300S, GSBD01300L, GSBD01300W	Engine Generators
GSBD01500S, GSBD01500L, GSBD01500W	Engine Generators
GSBD01700S, GSBD01700L, GSBD01700W, GSBD01750S, GSBD01750L	Engine Generators
GSBD01800S, GSBD01800L	Engine Generators
GSBD02000S, GSBD02000L	Engine Generators
GSBD02300S, GSBD02300L	Engine Generators
GSBD02500S, GSBD02500L	Engine Generators
GSBD02640S, GSBD02640L	Engine Generators
GSBD02800S, GSBD02800L	Engine Generators
GSBD03000S, GSBD03000L	Engine Generators
GSBD03300S, GSBD03300L	Engine Generators
GSBD30600S, GSBD30600L, GSBD30600LT GSBD30600W	Engine Generators
GSBD30633S, GSBD30633L, GSBD30633LT GSBD30633W	Engine Generators
GSBD30644S, GSBD30644L, GSBD30644LT GSBD30644W	Engine Generators

*Deborah Jennings-Conner*  
Deborah Jennings-Conner, VP Regulatory Services



UL LLC

Any information and documentation involving UL Mark services are provided on behalf of UL LLC (UL) or any authorized licensee of UL. For questions, please contact a local UL Customer Service Representative at <http://ul.com/aboutul/locations/>

# CERTIFICATE OF COMPLIANCE

**Certificate Number** MH63698  
**Report Reference** MH63698-20200103  
**Issue Date** 2020-JANUARY-08

**Issued to:** IGSA S A DE C V  
PROLONGACION PASEO DE LA REFORMA 2977  
COL CUAJIMALPA  
05000 MEXICO  
DF MEXICO

**This certificate confirms that representative samples of** SPECIAL-PURPOSE TANKS  
Secondary Containment Generator Base Tanks

Have been investigated by UL in accordance with the Standard(s) indicated on this Certificate.

**Standard(s) for Safety:** UL 142, STANDARD FOR STEEL ABOVEGROUND TANKS FOR FLAMMABLE AND COMBUSTIBLE LIQUIDS.  
UL 142A STANDARD FOR SPECIAL PURPOSE ABOVEGROUND TANKS FOR SPECIFIC FLAMMABLE OR COMBUSTIBLE LIQUIDS.  
CAN/ULC S601, STANDARD FOR SHOP FABRICATED STEEL ABOVEGROUND TANKS FOR FLAMMABLE AND COMBUSTIBLE LIQUIDS.

**Additional Information:** See the UL Online Certifications Directory at <https://iq.ulprospector.com> for additional information.

This *Certificate of Compliance* does not provide authorization to apply the UL Mark. Only the UL Follow-Up Services Procedure provides authorization to apply the UL Mark.

Only those products bearing the UL Mark should be considered as being UL Certified and covered under UL's Follow-Up Services.

Look for the UL Certification Mark on the product.



Bruce Mahrenholz, Director North American Certification Program  
UL LLC

Any information and documentation involving UL Mark services are provided on behalf of UL LLC (UL) or any authorized licensee of UL. For questions, please contact a local UL Customer Service Representative at <http://ul.com/aboutul/locations/>

