

**CONTROL SIMBOLOGY**

INSPECTION MEASURE

DRAWING REVISION

'C' = CUT 'D' = BEND

**TABLA DE TOLERANCIAS ESTANDAR DE NO ESPECIFICARSE**

TOLERANCES OF FINISHED PART		GENERAL TOLERANCES	
RANGO	TOLERANCIA	DIAMETROS	ANGULAR
0 mm - 999 mm	± 1 mm	NO ESPECIFICADO	± 2°
1000mm- 5m	± 2 mm		
5 m-12 m	± 3 mm	ESPECIFICADO	± 0.05
12m-100m	±10 mm		

MATERIAL	ITEM	WEIGHT (kg)	FINISH
N/A	N/A		CLEAN SURFACES WITHOUT BURRS

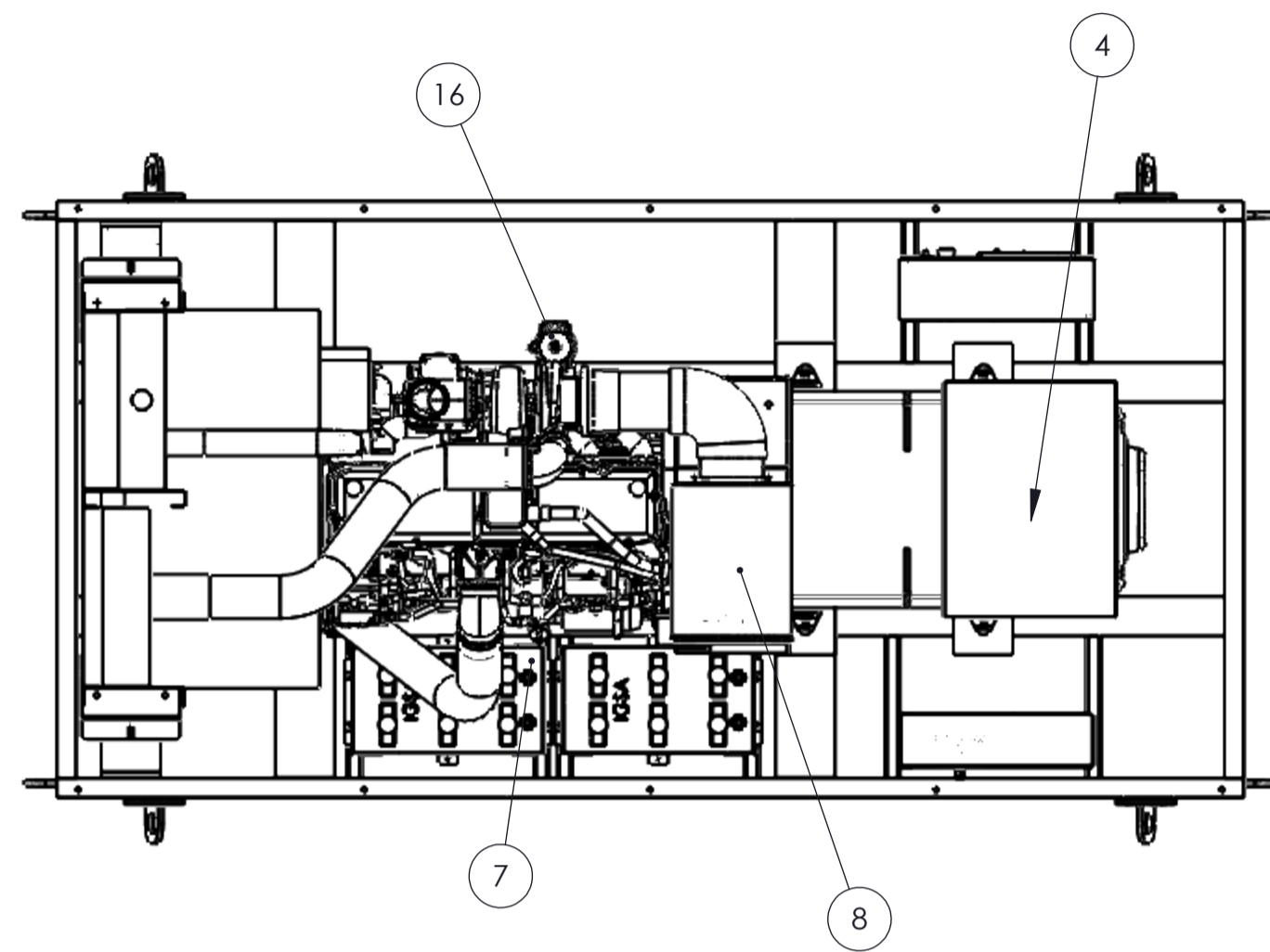

**TOP VIEW**

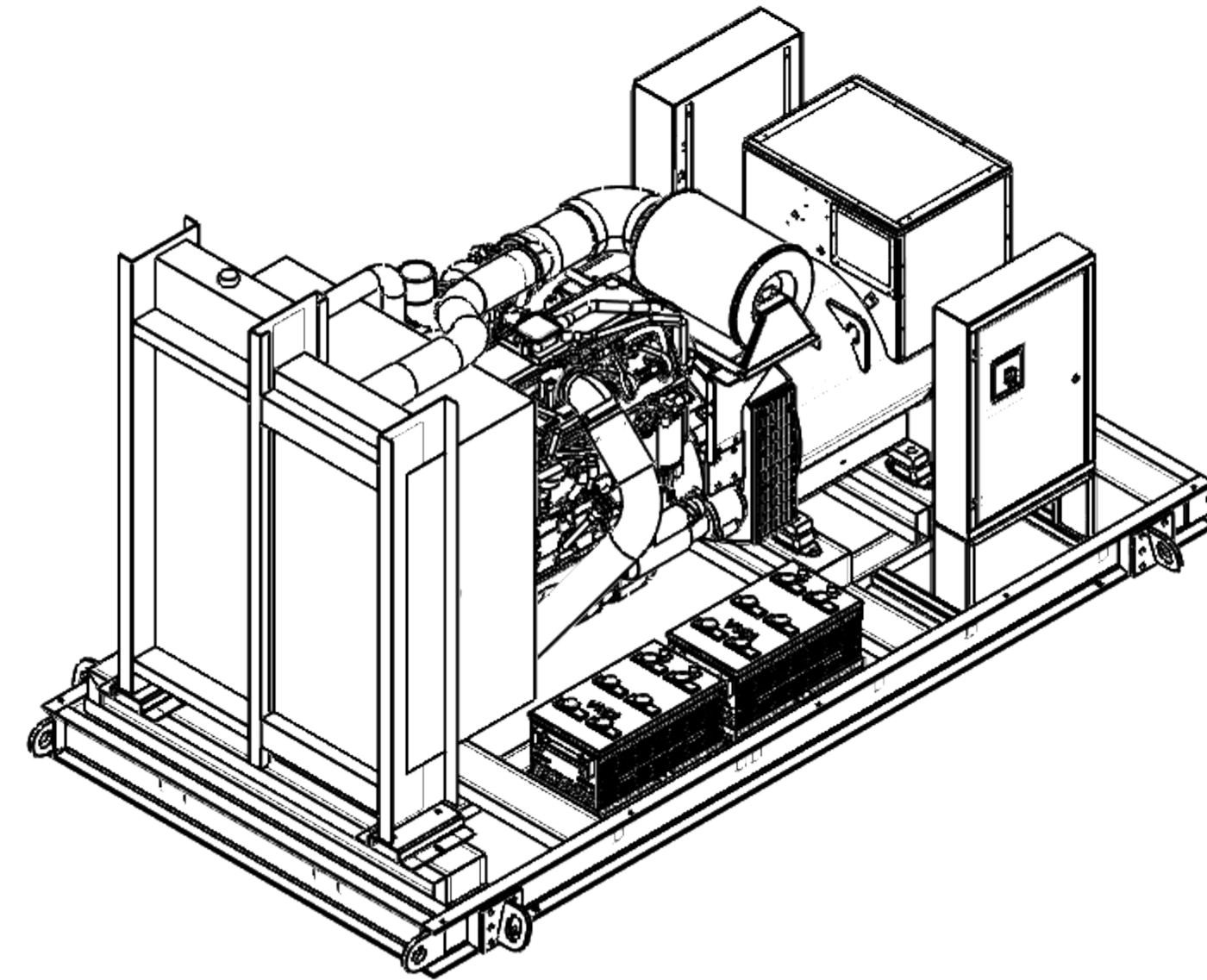

**ISOMETRIC VIEW**

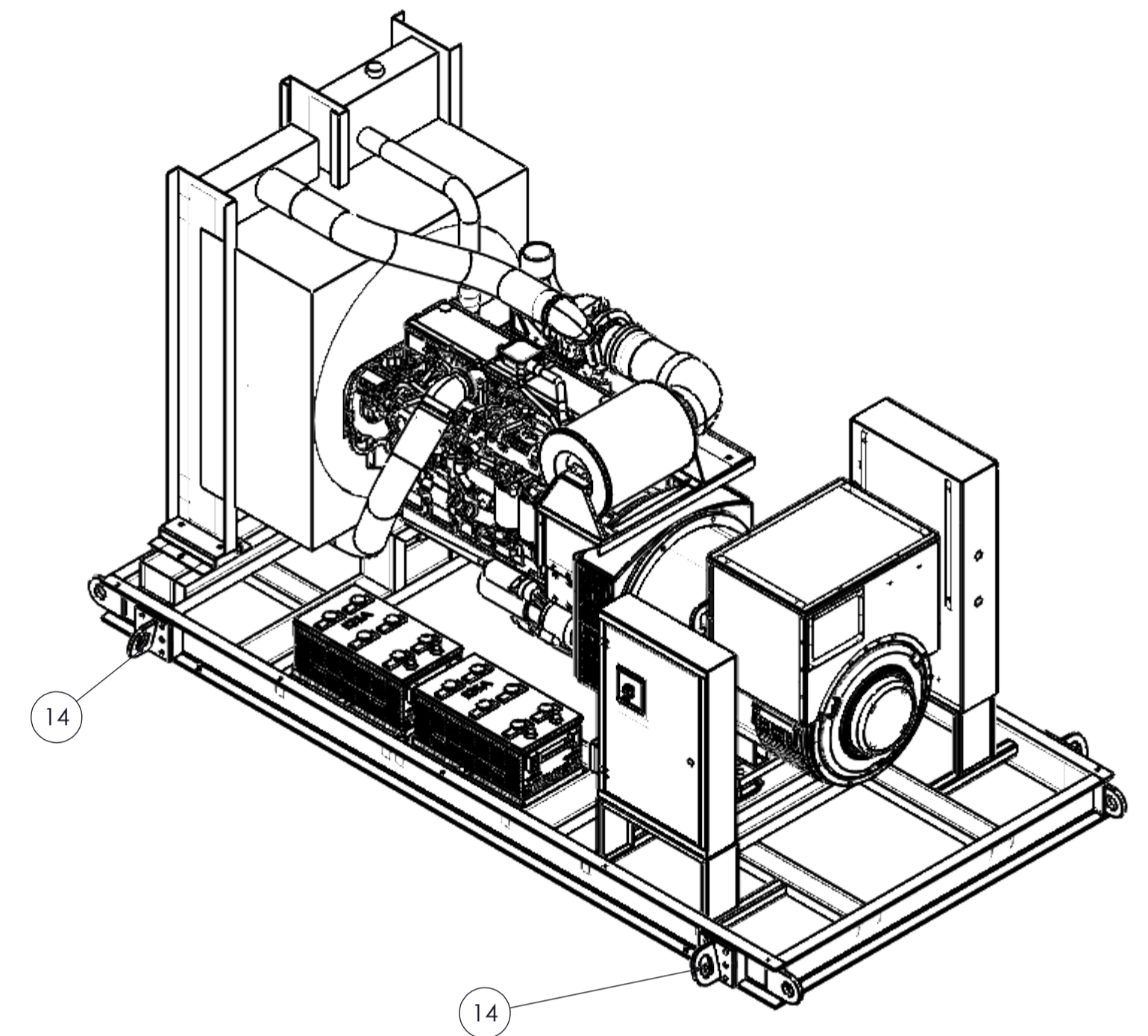

**ISOMETRIC VIEW**

MAX HEIGHT AND LENGHT DIMENSIONS

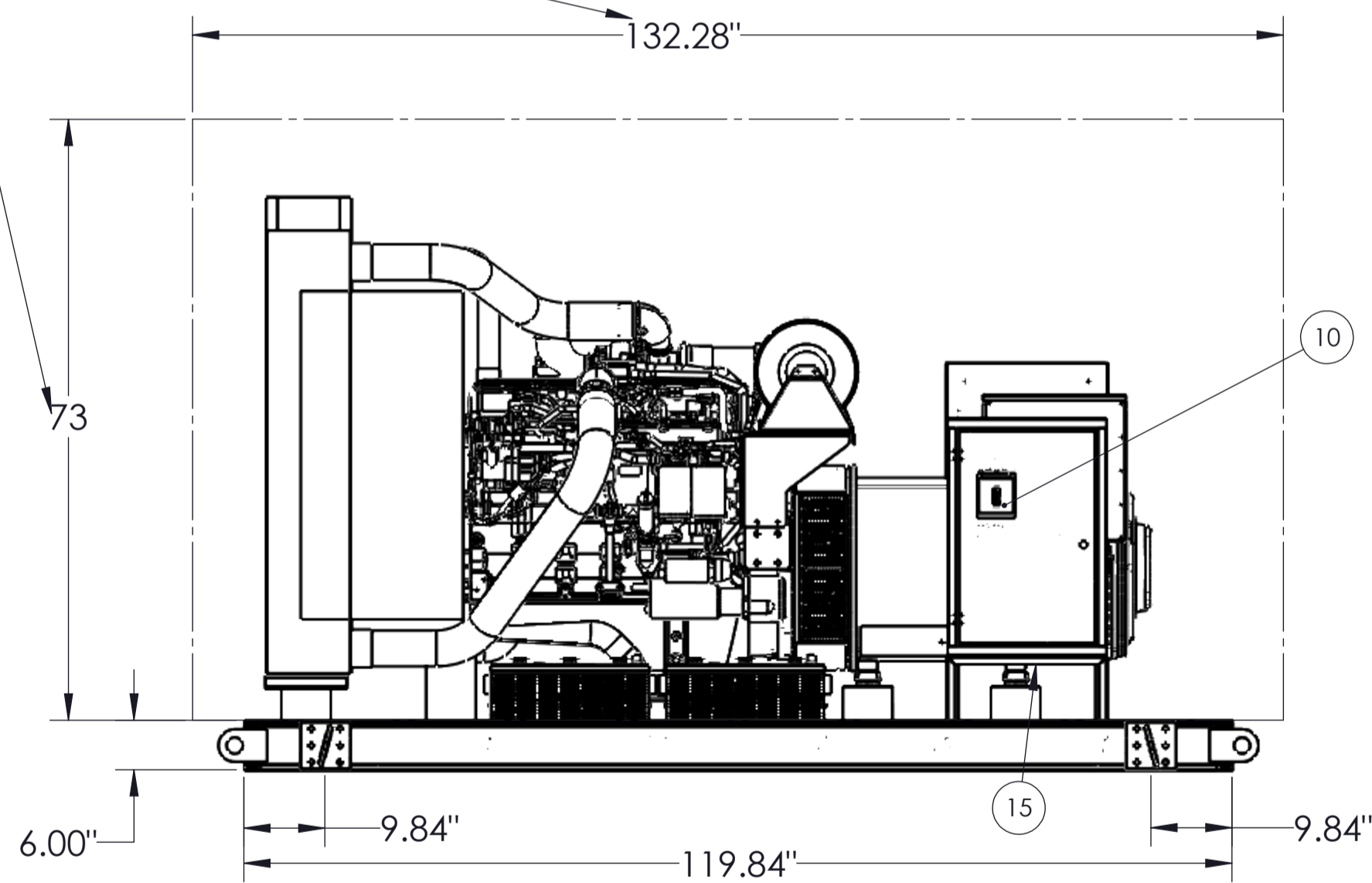

**RIGHT VIEW**

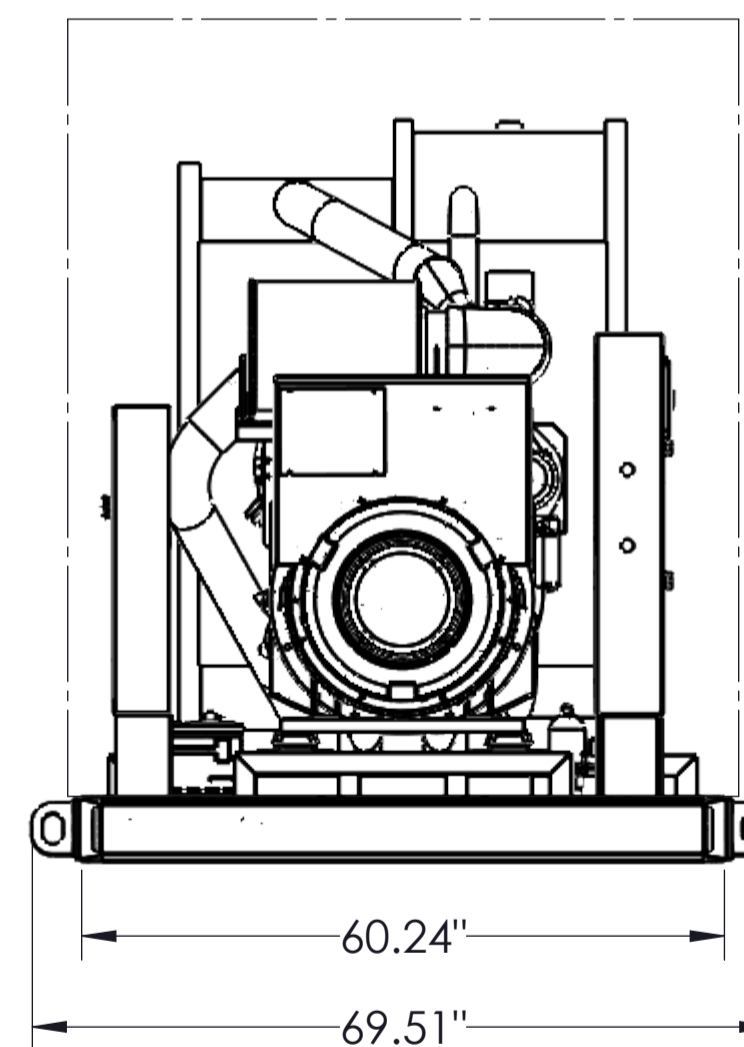

**REAR VIEW**

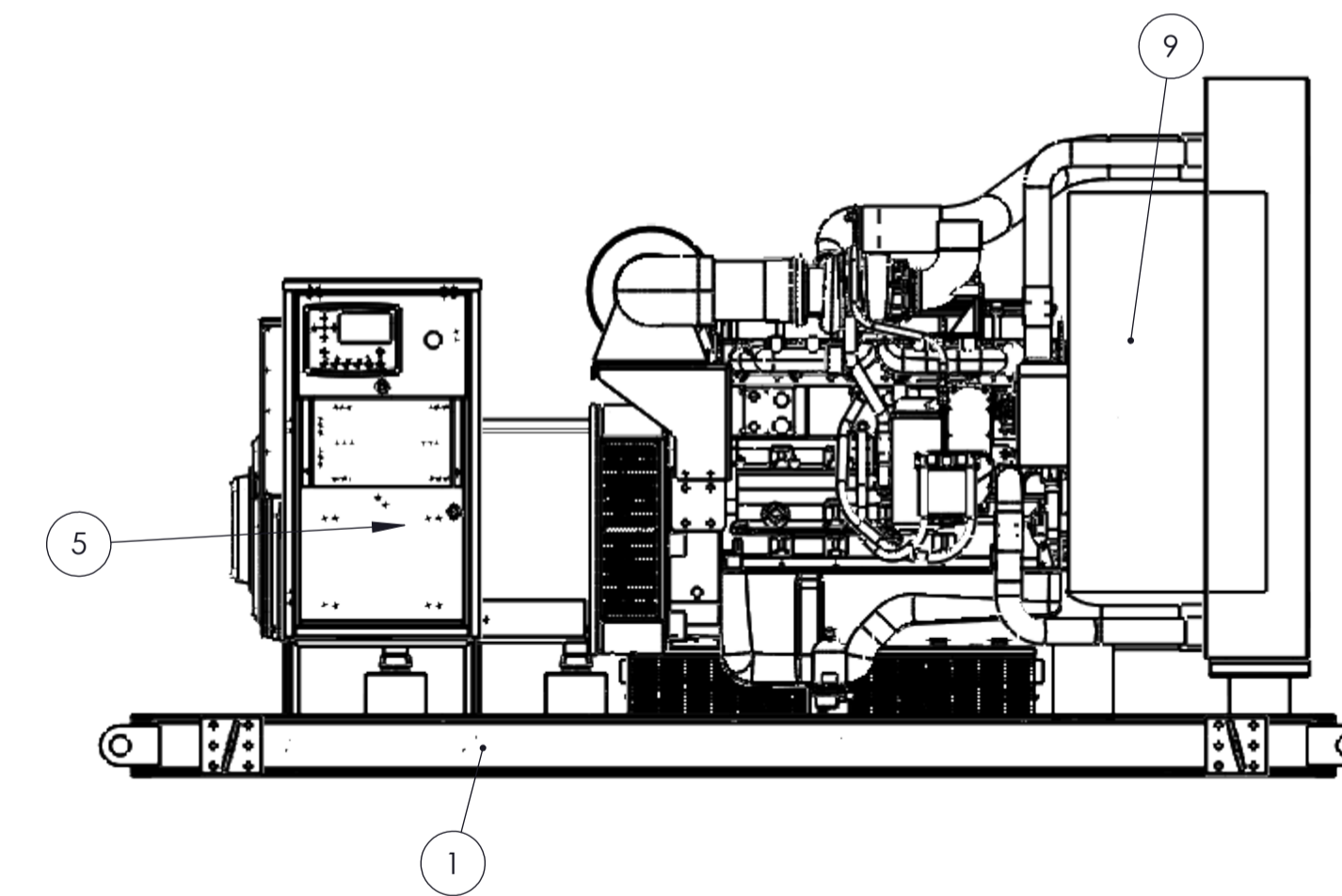

**LEFT VIEW**

ITEM NO.	DESCRIPTION
1	CHASSIS
2	MODULAR ACOUSTIC ENCLOSURE
3	ENGINE
4	ALTERNATOR
5	CONTROL PANEL
6	SILENCER
7	BATTERIES
8	AIR FILTER
9	RADIATOR
10	BREAKER
11	SIDE AIR INLET
12	FRONT AIR OUTPUT
13	REAR AIR INLET
14	LIFTING HOOK
15	OUTPUT CABLES
16	HEATER
17	COOLANT DRAINER
18	OIL DRAINER
19	EMERGENCY STOP

DEPTO.: <b>ENGINEERING</b>	DATE: 07/04/2019	DRAWN BY: ARG	REVIEWED BY: MBG	APPROVED BY: FJPR
ESCALE: N/A ACOT.: mm.	CUSTOMER: <b>STD UL</b>	DRAWING No: <b>EG VOLVO-STF 300kW 480 VAC 3PH</b>		
PART NAME: <b>BASE FRAME OF ENGINE VOLVO-STAMFORD 300KW/480VAC 3PH/ABB BREAKER T5N 600A</b>				REV.: 00
<b>IGSA S.A. DE C.V.</b> <small>HEAD QUARTERS: PASEO DE LA REFORMA No. 2977, COL. CUAJIMALPA, CP 05000, MEX. D.F.                  FACILITIES: HIGHWAY ANIMOLULCO-DOYOCACAC KM-8, LERMA EDO. DE MEXICO, CP 52740                  ENGINEERING DEPARTMENT, TEL.: 01 (55) 56269501 Ext.: 3018, 3020 &amp; 3026.</small>				SHEET 1 OF 2



**CONTROL SIMBOLOGY**

INSPECTION MEASURE

DRAWING REVISION

'C' = CUT 'D' = BEND

**TABLA DE TOLERANCIAS ESTANDAR DE NO ESPECIFICARSE**

TOLERANCES OF FINISHED PART		GENERAL TOLERANCES	
RANGO	TOLERANCIA	DIAMETROS	ANGULAR
0 mm - 999 mm	± 1 mm	NO ESPECIFICADOS	± 2°
1000mm- 5m	± 2 mm		
5 m-12 m	± 3 mm	ESPECIFICADOS	± 0.05
12m-100m	±10 mm		

MATERIAL	ITEM	WEIGHT (kg)	FINISH
N/A	N/A		CLEAN SURFACES WITHOUT BURRS

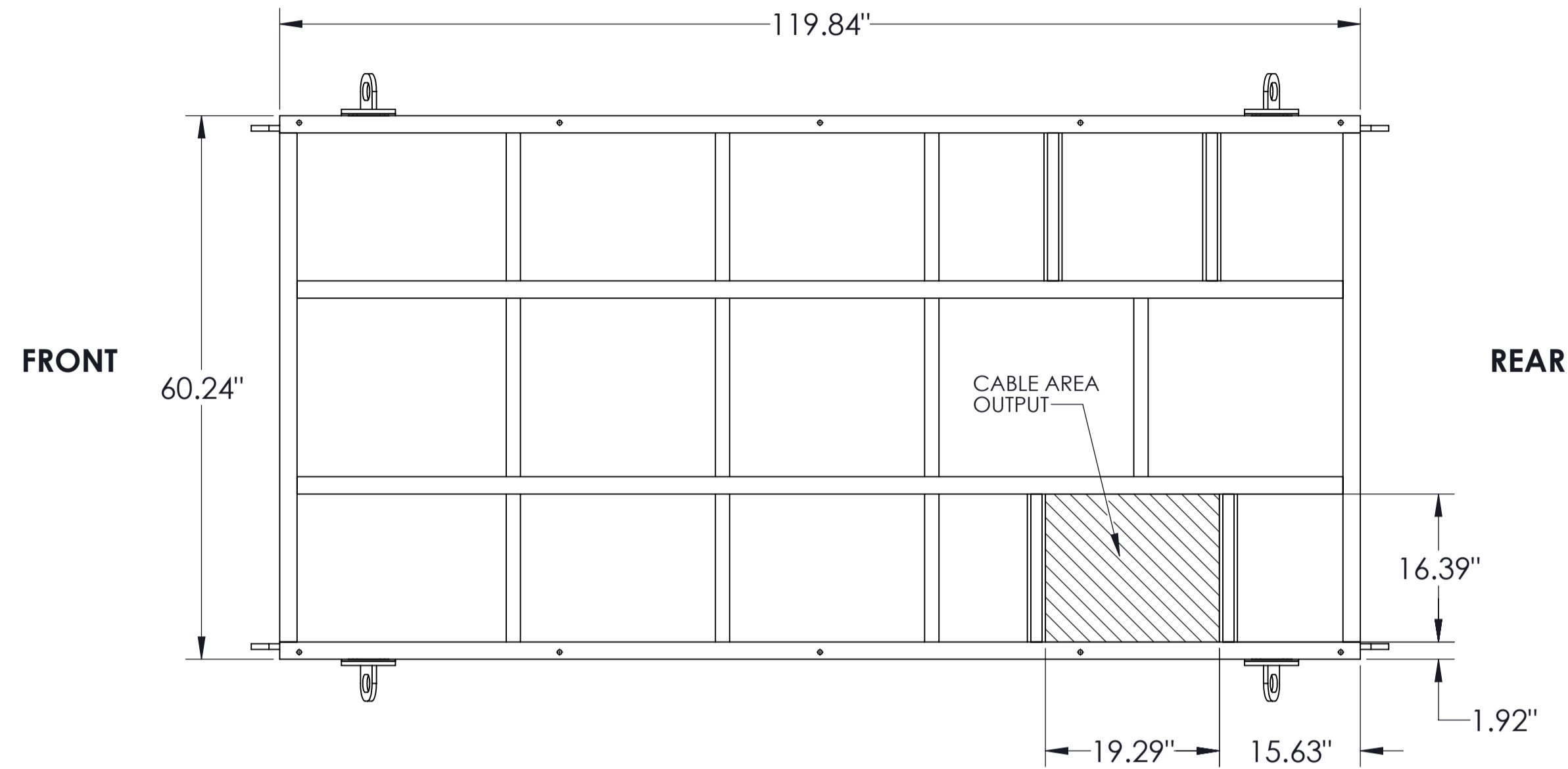

**CHASSIS TOP VIEW**

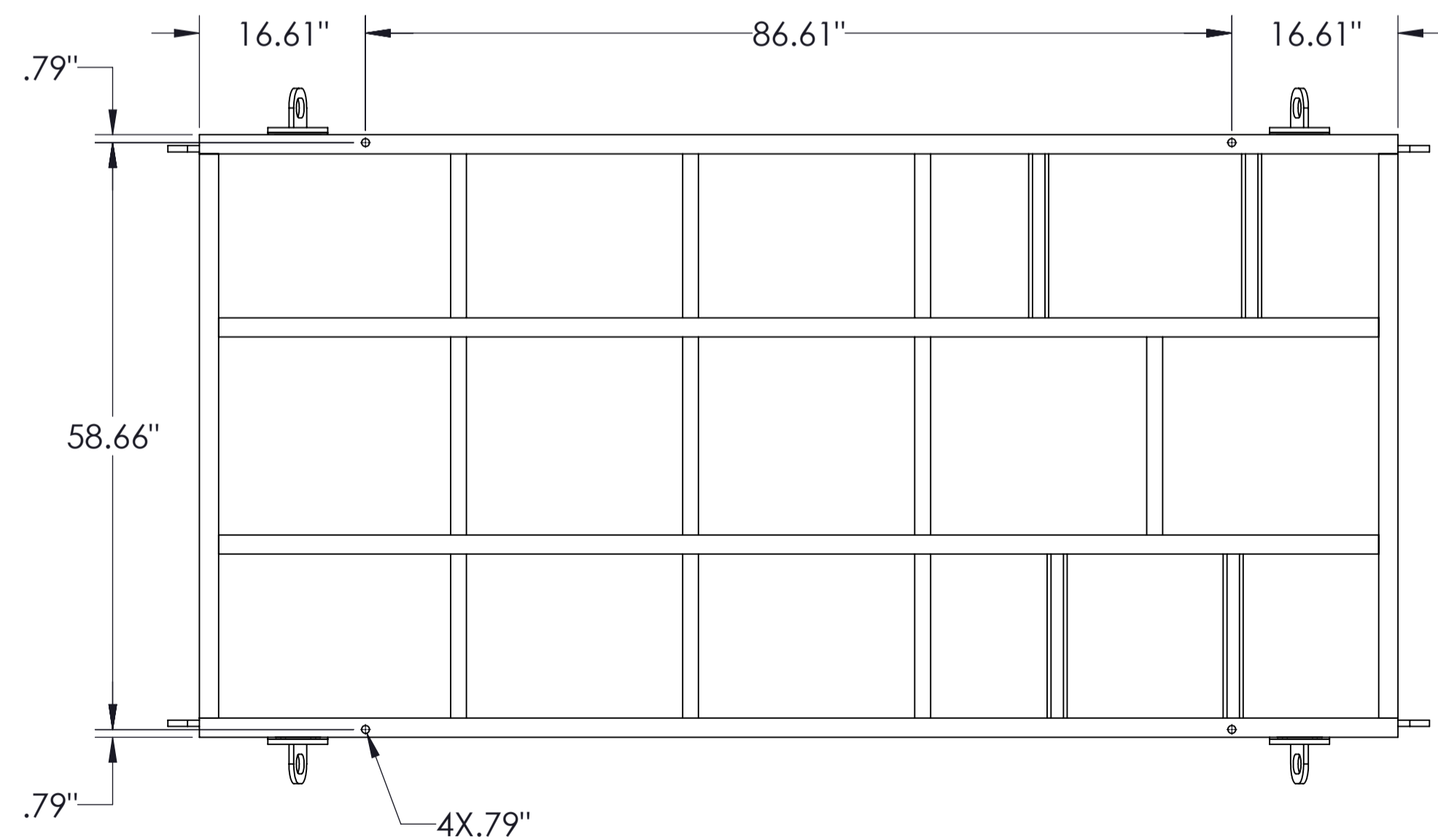
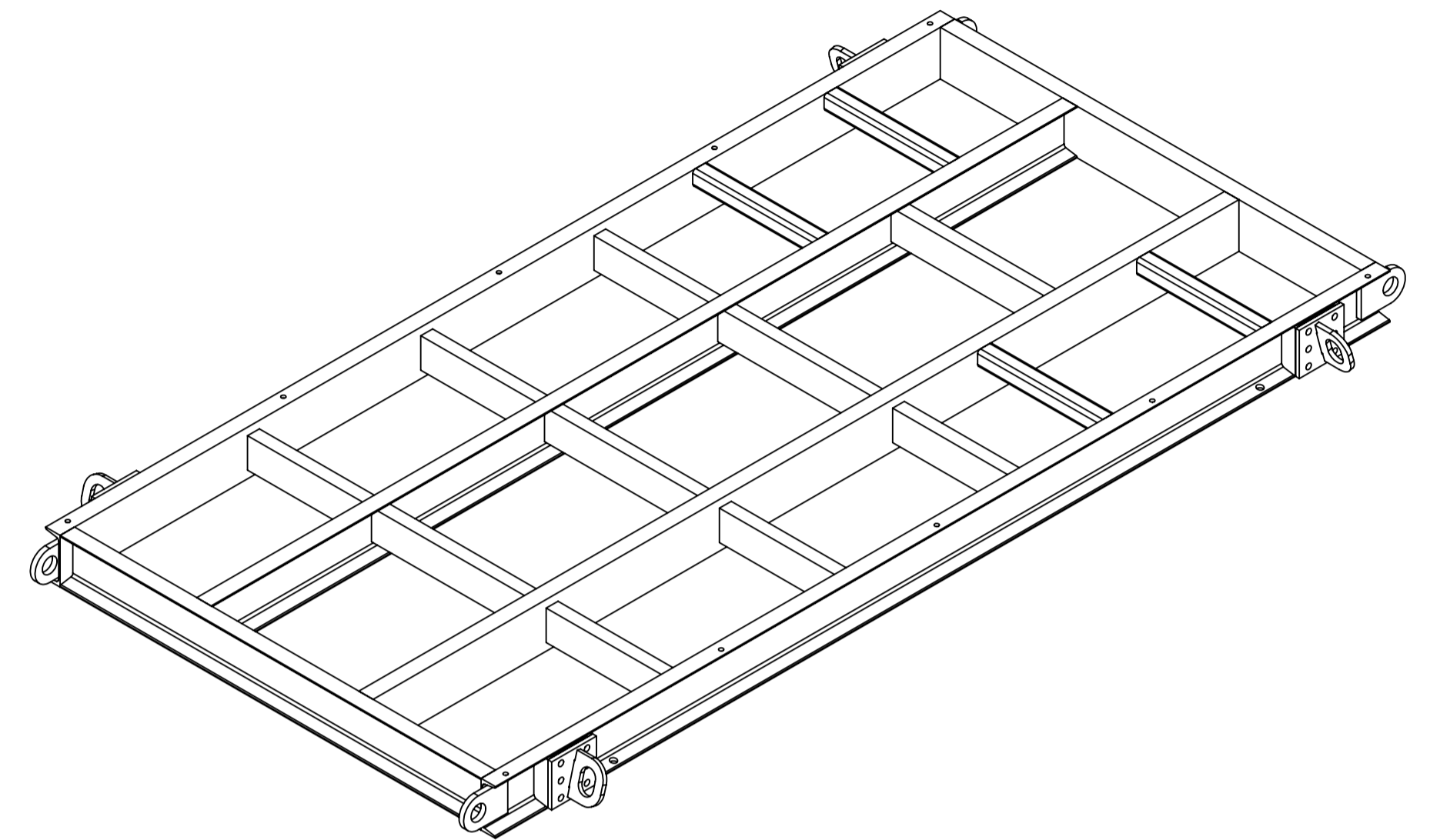

**CHASSIS BOTTOM VIEW ANCHORING TEMPLATE**

DEPTO.: <b>ENGINEERING</b>	DATE: 07/04/2019	DRAWN BY: ARG	REVIEWED BY: MBG	APPROVED BY: FJPR
ESCALE: N/A ACOT.: mm.	CUSTOMER: <b>STD UL</b>	DRAWING No: <b>EG VOLVO-STF 300kW 480 VAC 3PH</b>		
PART NAME: <b>BASE FRAME OF ENGINE VOLVO-STAMFORD 300KW/480VAC 3PH/ABB BREAKER T5N 600A</b>				REV.: 00
				SHEET 1 OF 2
<b>IGSA S.A. DE C.V.</b> <small>HEAD QUARTERS: PASEO DE LA REFORMA No. 2977, COL. CUAJIMALPA, CP 05000, MEX. D.F.                  FACILITIES: HIGHWAY ANIMOLULCO-OCYOYACAC KMS. LERMA EDO. DE MEXICO, CP 52740                  ENGINEERING DEPARTMENT: TEL.: 01 (55) 56265501 Ext.: 3018, 3020 &amp; 3025.</small>		<small>INFORMATION CONTAINED IN THIS DOCUMENT IS PROPEERTY OF IGSA COMPANY AND IT IS CLASSIFIED AS CONFIDENTIAL, HENCE IT CANNOT BE REPRODUCED TOTALLY OR PARTIALLY WITHOUT THE PREVIOUS AUTHORIZATION FROM IGSA S.A. DE C.V. MEXICO</small>		